



Advancing Healthcare Worldwide®

iReceptal Digital Surgical Suction System

Site Preparation, Installation, and Maintenance Guide

100~240 VAC Docking Station

REF iRD301

Instructions For Use

R_x ONLY

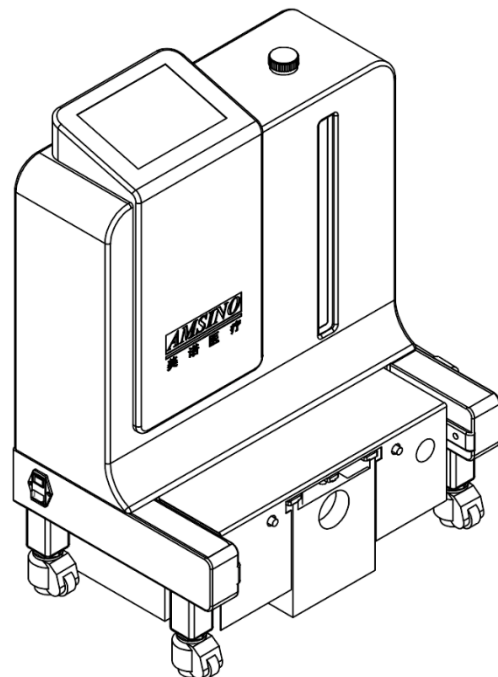

Contents

| | |
|---|----|
| Introduction..... | 3 |
| Conventions..... | 3 |
| Contact Information..... | 3 |
| Indications For Use..... | 3 |
| Contraindications For Use..... | 3 |
| Intended patient..... | 3 |
| For Use With..... | 4 |
| Accessories..... | 4 |
| Description..... | 4 |
| User/Patient Safety..... | 5 |
| General..... | 5 |
| Electrical Safety..... | 5 |
| Environmental/Biological..... | 6 |
| Features..... | 7 |
| Symbols..... | 8 |
| Instructions..... | 9 |
| To Install the Docker..... | 9 |
| 1. To Install the Docker and Connect Utilities..... | 10 |
| 2. To Apply Power, Water, and Detergent..... | 11 |
| To Test the Docker..... | 11 |
| 1. To Prepare the Rover..... | 12 |
| 2. To Prepare the Docker..... | 12 |
| 3. To Perform a Wash Cycle..... | 13 |
| To Shut Down the Docker..... | 14 |
| Inspection and Cleaning Maintenance..... | 14 |
| Add the Detergent..... | 15 |
| To Wipe Down the Docker..... | 16 |
| Storage and Handling..... | 16 |
| Disposal/Recycle..... | 17 |
| Troubleshooting..... | 17 |
| Error Messages..... | 18 |
| Specifications..... | 18 |
| Electromagnetic Compatibility..... | 20 |

Introduction

This Instructions For Use manual is the most comprehensive source of information for your product. Keep and consult this reference manual during the life of the product.

The iReceptal Digital Surgical Suction System Manifold is non-patient contacting, non-sterile, disposable device that provide a fluid path from the suction tubing lines of a iReceptal Digital Surgical Suction System to the receiving collection canisters of this system.

Conventions

The following conventions are used in this manual:

WARNING: A warning highlights a safety-related issue. ALWAYS comply with this information to prevent patient or healthcare staff injury.

CAUTION: A caution highlights a product reliability issue. ALWAYS comply with this information to prevent product damage.

NOTE: A note supplements and/or clarifies procedural information.

Contact Information

For additional information, including safety information, or in-service training, contact your AMSINO sales representative or call AMSINO iReceptal Customer Service.

Indications For Use

The iReceptal Digital Surgical Suction System is intended to be used in the operating room, pathology, surgical centers, and doctor's offices to collect and dispose of surgical fluid waste as well as collect smoke generated from electrocautery or laser devices.

Contraindications For Use

The iReceptal Digital Surgical Suction System is contraindicated against:

- Connection directly to chest tubes.
- Connection to closed wound drainage systems.

Intended patient

The general patient population is anyone excluding newborn subject to general surgeries where the device can be used.

For Use With

The following components are required to be used with the equipment described in this manual to create a complete system:

| Description | REF |
|-------------------------------|------------------------------------|
| iReceptal 3 Rover | iRR301 100~120V iRR302 220~240V |
| iReceptal 3 Docking Detergent | iRC003 |

Accessories

This section describes system components that may be ordered to replace original equipment that is damaged, worn, or must be replaced. This section may also contain optional components used with the system.

The following AMSINO-approved accessories are sold separately:

| Description | REF |
|-------------------------------|-----------|
| iReceptal 3 Docking Detergent | iRC003 |
| Power Cord (US) | iRA105-01 |
| Power Cord (UK) | iRA106-01 |
| Power Cord (EU) | iRA107-01 |

NOTE: For a complete list of accessory information, contact your AMSINO sales representative or call AMSINO iReceptal Digital Surgical Suction System Customer Service.

Description

The iReceptal Docking Station (docked) is a component of the iReceptal Digital Surgical Suction System. The Rover (rover), another component of the system, is a mobile unit used to suction and collect fluid waste and surgical smoke from a surgical site in an operating room.

After collection, the rover is relocated and mated to the docked. Once the rover is connected to the docked, the emptying of the fluid waste and cleaning of the canisters occurs automatically (Figure 1).

The rover chambers are rinsed with clean water and iReceptal Docking Detergent REF iRC003 to clean the chambers of any residual fluid waste (Figure 2).

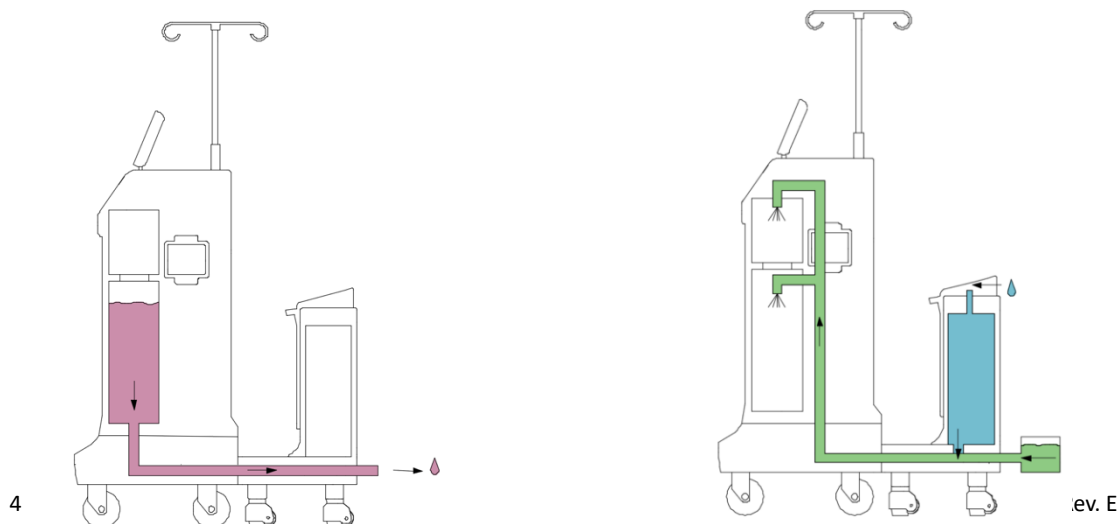

User/Patient Safety

WARNINGS:

General

- Before using any system component, or any component compatible with this system, read and understand the instructions. Pay particular attention to WARNING information. Become familiar with the system components prior to use.
- Only trained and experienced healthcare professionals may use this equipment.
- Healthcare professionals should be thoroughly familiar with the instructions for use, handling characteristics, and the indicated and intended uses of this equipment. Contact your AMSINO sales representative or AMSINO iReceptal Digital Surgical Suction System Customer Service for in-service training.
- DO NOT disassemble, modify, service, or repair any system component or accessory, unless otherwise specified. Call AMSINO iReceptal Digital Surgical Suction System Customer Service.
- Upon initial receipt and before each use, inspect each component for damage. DO NOT use any equipment if damage is apparent or the inspection criteria are not met. See the Inspection and Maintenance section for inspection criteria.
- ALWAYS operate the equipment within the specified environmental condition values. See the Specifications section.
- MANUFACTURER will provide circuit diagrams, component part lists, descriptions, calibration instructions to assist to SERVICE PERSONNEL in parts repair.
- Do not use iReceptal Digital Surgical Suction System in the presence of magnetic resonance imaging (MRI) devices.

Electrical Safety

- Use only AMSINO-approved system components and accessories, unless otherwise specified. Using other electronic components and accessories may result in increased electromagnetic emissions or decreased electromagnetic immunity of the system.
- Take special precautions regarding electromagnetic compatibility (EMC) when using medical electrical equipment like this system. Install and place this system into service according to the EMC information contained in this manual. See the Specifications section. Portable and mobile radio frequency (RF) communications equipment can affect the function of this system.
- ELECTRICAL SHOCK HAZARD-ALWAYS connect this equipment to a hospital-grade, facility power receptacle with protective earth (ground). Failure to comply may cause electrical shock and result in patient

or healthcare staff injury.

- Please take attention that changes or modification not expressly approved by the party responsible for compliance could void the user's authority to operate the equipment.
- This device complies with Part 15 of the FCC Rules. Operation is subject to the following two conditions:
 - (1) This device may not cause harmful interference, and
 - (2) This device must accept any interference received, including interference that may cause undesired operation.
- This device complies with Industry Canada licence-exempt RSS standard(s). Operation is subject to the following two conditions:
 - (1) this device may not cause interference, and
 - (2) this device must accept any interference, including interference that may cause undesired operation of the device.
- Le présent appareil est conforme aux CNR d'Industrie Canada applicables aux appareils radioexempts de licence. L'exploitation est autorisée aux deux conditions suivantes :
 - (1) l'appareil ne doit pas produire de brouillage, et
 - (2) l'utilisateur de l'appareil doit accepter tout brouillage radioélectrique subi, même si le brouillage est susceptible d'en compromettre le fonctionnement.
- This equipment complies with FCC/IC RSS-102 radiation exposure limits set forth for an uncontrolled environment. This equipment should be installed and operated with minimum distance 20cm between the radiator & your body.
- ce matériel est conforme aux limites de dose d'exposition aux rayonnements, FCC / CNR-102 énoncée dans un autre environnement.cette equipment devrait être installé et exploité avec distance minimale de 20 entre le radiateur et votre corps.
- Under Industry Canada regulations, this radio transmitter may only operate using an antenna of a type and maximum (or lesser) gain approved for the transmitter by Industry Canada. To reduce potential radio interference to other users, the antenna type and its gain should be so chosen that the equivalent isotropically radiated power (e.i.r.p.) is not more than that necessary for successful communication.
- Conformément à la réglementation d'Industrie Canada, le présent émetteur radio peut fonctionner avec une antenne d'un type et d'un gain maximal (ou inférieur) approuvé pour l'émetteur par Industrie Canada. Dans le but de réduire les risques de brouillage radioélectrique à l'intention des autres utilisateurs, il faut choisir le type d'antenne et son gain de sorte que la puissance isotrope rayonnée équivalente (p.i.r.e.) ne dépasse pas l'intensité nécessaire à l'établissement d'une communication satisfaisante.
-

Environmental/Biological

- FIRE HAZARD – DO NOT use this equipment in areas in which flammable anesthetics or flammable agents are mixed with air, oxygen or nitrous oxide. Failure to comply may cause a fire and result in burn injury or property damage.
- BLOODBORNE PATHOGEN HAZARD
 - The Bloodborne Pathogens Standard provided by the United States Occupational Safety and Health Association (US OSHA 29 CFR 1910.1030) requires those with employees having occupational exposure to potentially infectious materials to establish a written Exposure Control Plan. The Exposure Control Plan is designed to eliminate or minimize employee exposure through use of personal protective equipment (PPE), appropriate vaccinations (e.g. hepatitis B), and other control

measures.

- ALWAYS wear PPE when operating or handling this equipment.
- ALWAYS follow local regulations regarding proper handling and disposal of biohazard waste.

Failure to comply may cause infection and result in healthcare staff injury.

- CONTAMINATION HAZARD-ALWAYS follow local regulations for safe handling, recycling, and disposal of biohazard fluid waste and equipment. See Disposal/Recycle section. Failure to comply may cause environmental contamination and result in injury.

Features

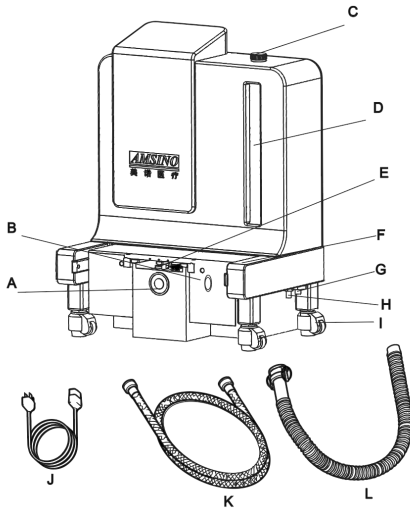

Figure 3 Docking Station Front view

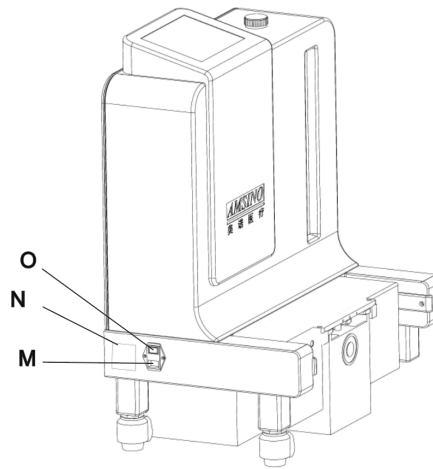











Figure 4 Docking Station Back view

| | |
|---|---|
| A | Magnet– Provide for the automatic connection of the rover to the docker. |
| B | Infrared Communication Port – Allow infrared data transfer between the docker and rover. Data transfer is necessary during the docking procedure. |
| C | Detergent canister lid – Allows add detergent into the canister |
| D | Detergent canister- Stores the detergent |
| E | Fluid Connectors (two) –One connector allows fresh water to enter the rover. The other connector provides for the disposal of waste water from the rover. |
| F | Guides (two) – Facilitate the alignment of the rover to the docker. |
| G | Waste Outlet Port – Allows for the disposal of fluid waste from the rover when the rover is connected to the docker. |
| H | Water Inlet Port – Allows fresh water to enter the rover when the rover is connected to the docker. |
| I | Fixing Casters (four)--Allows adjust the height of each docking station to align with the rover. Increase caster height by turning the dial counterclockwise. Decrease caster height by turning the dial clockwise. |
| J | Power Cord – Allows for the connection of facility electrical power to the docker. Power cord configurations may vary. See the Accessories section for options. |
| K | Water Inlet Hose – Allows fresh water to flow from the facility water source to the docker water inlet port. |

| | |
|---|--|
| L | Waste Outlet Hose – Allows fluid waste to flow from the docker waste outlet port to the drain of the facility waste disposal system. |
| M | Power Cord Receptacle – Allows for the connection of facility power using the docker power cord. |
| O | Power Switch – Allows for the application or removal of facility power. |
| N | Specification Label |

Symbols

The following symbols appear on the device and/or its labeling. For more information, see “Technical specifications”

| Symbol | Description |
|---|--|
|  | ON (POWER) |
|  | OFF (POWER) |
|  | ALTERNATING CURRENT (AC) |
|  | General warning |
|  | Consult instructions for use |
|  | Follow instructions for use |
|  | This symbol is located near the protective ground locations on this device |
|  | DETERGENTADD PORT |
|  | WASTE OUTLET PORT |
|  | WATER INLET PORT |

Instructions

To Install the Docker



WARNING: HEAVY EQUIPMENT – ALWAYS have more than one person unpack and move this equipment from the shipping pallet. See the Specifications section for rover weight. Failure to comply may result in personal injury.

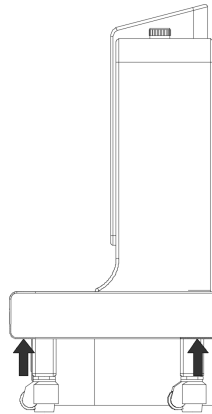

Figure 5 Docker Lift Points

CAUTIONS:

- Make sure the pressure and temperature values of the facility water supply are within the required specified ranges. See the Specifications section.
- If mounting the docker to a wall, make sure no gap exists between the docker mounting bracket and the wall. ALWAYS align the mounting hardware (not supplied) with the wall studs to make sure the docker is mounted to the wall securely. Failure to comply may cause inadvertent docker movement and result in wall or product damage.
- ALWAYS use the correct power cord. Configurations may vary. See the Accessories section for power cord options

NOTES:

- Only individuals trained and experienced in the maintenance of reusable medical devices should install, inspect, and test this equipment.
- The docker is installed in a utility closet or disposal area with access to electrical power, a water supply, and a fluid waste drain. The healthcare facility is responsible for the preparation of the installation site and the availability of utilities. See the Specifications section for electrical power, water, and drainage requirements. Make sure the installation area meets utility and space requirements.
- If the installation site does not meet local ventilation requirements, obtain and install a ventilation device that will meet the necessary local requirements.
- The docker is equipped with an internal backflow prevention device. See the Specifications section for details. Refer to local plumbing codes to determine whether an external backflow prevention device is also

required.

- Make sure the plumbing configuration is NOT susceptible to water hammer conditions.
- Make sure the waste outlet hose is connected properly to minimize the escape of noxious fumes and odors.

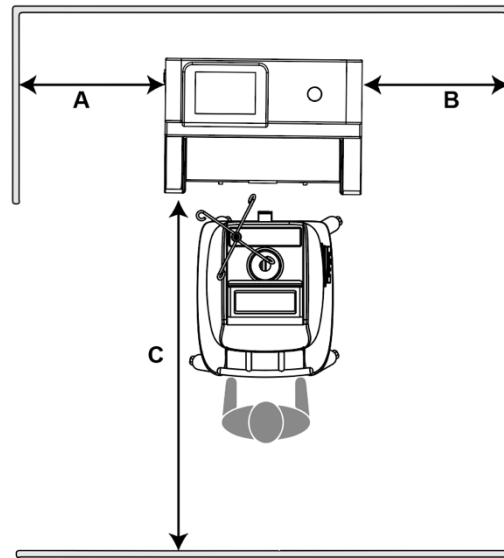

Figure 6 Minimum Floor Space Requirements

| | | |
|---|----------------------|------------------------|
| A | Left-Side Clearance | No minimum requirement |
| B | Right-Side Clearance | 15 cm |
| C | Front Clearance | 120cm |

1. To Install the Docker and Connect Utilities

- Place the docker on the floor and against a wall with access to electrical power, water, and a fluid waste disposal drain.
- Recommended: Install mounting screws (not supplied) through the mounting bracket of the docker and secure the docker to the wall.

NOTE: If allowed by current local building and electrical codes, mounting the docker to the wall is strongly recommended. The docker is not to be installed in a patient environment.

- Connect the water inlet hose between the water inlet port of the docker and the facility water supply.
- Connect the waste outlet hose to the waste outlet port of the docker and the drain emptying into the fluid waste disposal system.

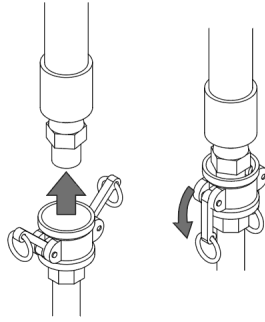

Figure 7 To Connect the Waste Outlet Hose

e. Connect the power cord between the electrical receptacle of the docker and the facility electrical power source.

2. To Apply Power, Water, and Detergent

- a. Press the power switch ON. Make sure the power switch illuminates.
- b. Open the facility water valve to allow water to flow to the docker. Inspect the water supply connections for any leaks. Repair any plumbing to stop leakage if necessary.
- c. Unscrew the lid of the detergent canister and pour the detergent into the detergent canister. see the instructions for use supplied with the Docking Detergent REF iRC003. See the Accessories section

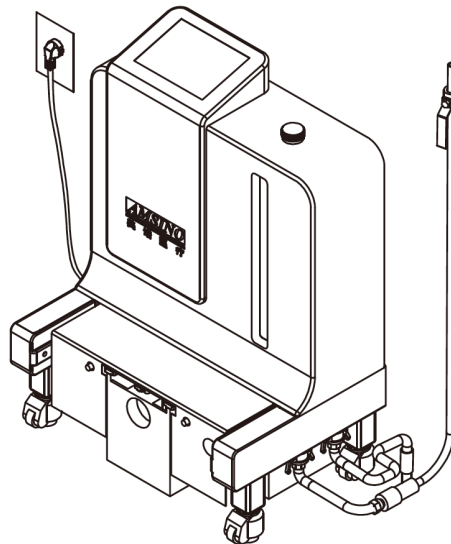

Figure 8 To Apply Power, Water, and Detergent

To Test the Docker



WARNING: ALWAYS keep hands out and away from the mating surfaces of the rover and docker during the docking procedure to avoid a pinch point hazard.

CAUTIONS:

- DO NOT put any objects, including hoses, tubes, towels or detergent bottles, on or over the docker enclosure. Failure to comply may cause corrosion.
- DO NOT allow fluid of any kind to spill directly onto the exterior surface of the electrically-powered docker. Failure to comply may cause corrosion or product failure.

NOTES:

- Only individuals trained and experienced in the maintenance of reusable medical devices should install, inspect, and test this equipment.
- Make sure the rover is operating properly. See the instructions for use supplied with the rover.
- While the rover is docked, DO NOT lock the rover casters.

1. To Prepare the Rover

- Connect the rover to facility electrical power using the power cord.
- Push the power switch to the ON position.
- Read the WARNING message on the user interface, then tap the OK key to access the CONTROL screen.
- Install a disposable manifold into manifold port.
- Attach a suction tube to one manifold port on manifold. Make sure all the other manifold ports are capped.
- Place the attached suction tube into a sink filled with water.
- Push the rover SUCTION button to start the vacuum pump.
- Adjust the SUCTION SETTING to initiate suction and transfer about two liters of water into the canister.
- After the canister is filled with two liters of water, push the rover power switch to the OFF position.
- Disconnect the rover from facility electrical power. Wrap the power cord around the cord bracket.
- Remove the disposable manifold and suction tube.

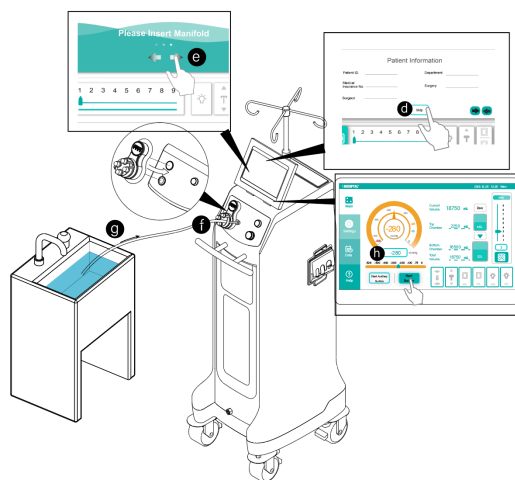

Figure 9 To Prepare the Rover

2. To Prepare the Docker

- Make sure the power switch is in the ON position and illuminated.

- b. Make sure the canister of Detergent has enough detergent to perform a wash cycle.

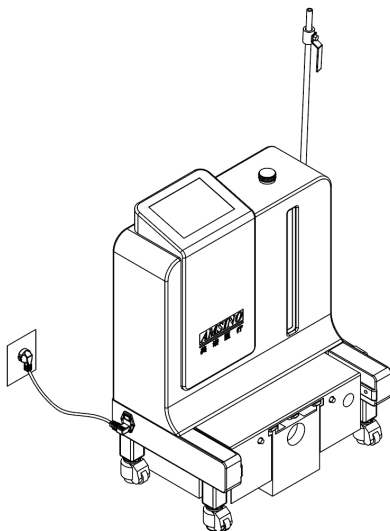

Figure 10 To Prepare the Docker

3. To Perform a Wash Cycle

- a. Push the rover toward the docker and between the guides until the rover and docker attach automatically.
- b. As the rover and docker attached together, the Wash Cycle View will display automatically and “Docking in place” voice message will be heard. From the Wash Cycle View select a cycle by tapping the related BUTTON. For the wash cycle options, refer to the wash cycle options table.

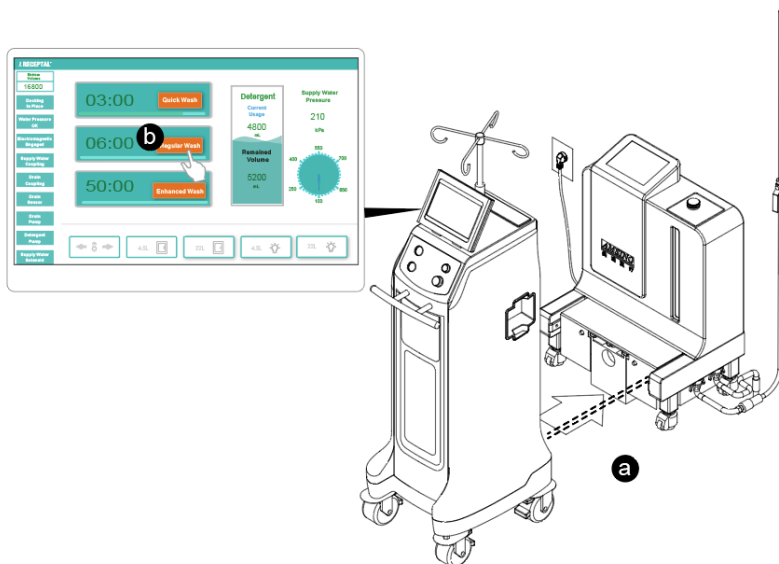

Figure 11 To perform a wash cycle

NOTES:

- During the first rover docking procedure, the information on the user interface display may appear inconsistent. The procedure may also take a few more minutes than specified in the Wash Cycle Options table. Both conditions are normal and temporary.
- If a specific wash cycle is not selected within ten seconds, the “Wash” cycle will be performed automatically. See the Wash Cycle Options table.

- To exit the current wash cycle, push the “Stop Suction/Stop Docking” button to terminate the current a wash cycle and the rover detaches from the docker automatically. Pull the rover away from the docker. And dock again, select the needed wash cycle.

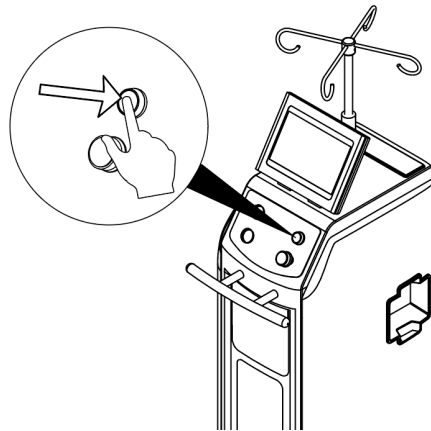

Figure 12 To cease the current wash Cycle

Wash Cycle Options

| CYCLES | DESCRIPTION | TIME (approx.) |
|---------------|--|----------------|
| Wash | Cycle drains the contents, applies detergent to the interior walls of both chambers, and rinses the detergent with water. | 6 minutes |
| Quick Drain | Cycle drains the contents of both chambers. | 3minutes |
| Extended Wash | Cycle drains the contents, applies detergent to the interior walls of both chambers and rinses the detergent with water. Intermittent periods of soaking occur during the cycle. | 50 minutes |

- During the wash cycle, inspect all the docker plumbing and connections for any leakage. If leakage occurs, repair as required.
- After the cycle is complete, the rover detaches from the docker automatically. Pull the rover away from the docker.

NOTE: After successfully testing, the docker is ready for use.

To Shut Down the Docker

The docker does not need to be shut down between uses. To remove facility power from the docker, push the power switch to the OFF position.

Inspection and Cleaning Maintenance

⚠ WARNINGS:

- Upon initial receipt and before each use, inspect each component for damage. DO NOT use any equipment if damage is apparent or the inspection criteria are not met.

- DO NOT disassemble, modify, service, or repair any system component or accessory, unless otherwise specified. Call AMSINO iReceptal Customer Service.

NOTES:

- Only individuals trained and experienced in the maintenance of reusable medical devices should install, inspect, and test this equipment.
- For service, contact your AMSINO sales representative or call AMSINO iReceptal Customer Service. Outside the US, contact your nearest AMSINO subsidiary.
- Maintenance documentation for this equipment is available upon request to AMSINO-authorized service personnel only.

| INTERVAL | INSPECTION CRITERIA | ACTION |
|---|--|---|
| Before initial use | Make sure the equipment has been tested before first use. | See the To Test the Docker section. |
| Before each use and after each cleaning | Check equipment for damage or missing components. | If damage is apparent, replace the equipment. |
| | Check power cord for cuts. | |
| | Check power cord receptacle for bent pins or bent contacts. | |
| Six months | Check the plumbing connections and hoses for leaks. | Repair any plumbing to stop leakage as required. Replace leaking hoses as required. |
| As required | Check the two infrared communication ports for any obstructions. | Remove any obstruction covering the infrared communication ports, including hoses, tubes, and towels. |
| | Check the level of the detergent in the detergent canister. | Add the detergent into the detergent canister as required. |

NOTE: If any component must be discarded, see the Disposal/ Recycle section.

Add the Detergent

 **WARNINGS:**

- The iReceptal Detergent REF iRC003 is an irritant to eyes and skin. ALWAYS wear protective gloves and eye protection to avoid contact with skin and eyes.
- In case of contact with eyes, rinse eyes immediately with plenty of water. See the Material Safety Data Sheet (MSDS) supplied with the iReceptal Docking Detergent for first aid information.
- DO NOT spill the detergent. Spills will be slippery and may result in a slip/fall hazard.
- ALWAYS follow the current local regulations governing environmental protection to recycle or dispose of the bottle. DO NOT reuse the empty container.

CAUTION: Use only AMSINO iReceptal Detergent REF iRC003 with the docker. Failure to comply will result in damage to rover and docker internal components.

1. Remove the detergent canister lid tube from the docker.
2. Pour the detergent into the detergent canister from the detergent bottle and dispose of the container properly.

Cleaning Maintenance

CAUTIONS:

- DO NOT immerse any system component in liquid. DO NOT allow liquids or moisture to enter any electrical connection.
- DO NOT sterilize any system component.
- DO NOT use solvents, lubricants, or other chemicals, including glutaraldehyde or similar chemical cleaners, unless otherwise specified.
- Use of unapproved disinfectants may cause system damage.

Recommended Equipment

- Personal Protective Equipment (PPE) as recommended by the disinfectant supplier (minimum: gown, gloves, face/eye shield)
- Soft, lint-free cloth
- Environmental Protection Agency (EPA) registered disinfectant with a claim for activity against Hepatitis B. The following disinfectants have been validated for use with the AMSINO iReceptal 3 Waste Management System:
 - Sodium Hypochlorite Based - Clorox Clean-Up. Disinfectant Cleaner with Bleach (EPA Reg. #67619-1)
 - Quaternary Ammonium Based - CaviCide. (EPA Reg. #46781-6)

To Wipe Down the Docker

1. Wipe the external surfaces of the docker with a soft, lint-free cloth moistened with a non-abrasive, hospital disinfectant prepared according to the manufacturer's instructions. Make sure all surfaces remain visibly wet at room temperature.
2. Remove any excess disinfectant solution using a soft, lint-free cloth moistened with water if required by the instructions supplied by the disinfectant manufacturer.
3. Thoroughly clean the docker's infrared communication ports to make sure the rover and docker can communicate and function properly.
4. Inspect the docker. See the Inspection and Maintenance section.

Storage and Handling

CAUTIONS:

- ALWAYS store and transport the equipment within the specified environmental condition values throughout its useful life. See the Specifications section.

- ALWAYS call AMSINO iReceptal Customer Service before transporting or storing this equipment in freezing conditions. Failure to comply will cause the expansion of frozen internal fluid to damage the equipment.

To ensure the longevity, performance and safety of this equipment, use of the original packaging material is recommended when storing or transporting this equipment.

Disposal/Recycle

 WARNING:

BLOODBORNE PATHOGEN AND CONTAMINATION HAZARDS –

- ALWAYS follow local regulations for safe handling, recycling, and disposal of biohazardous fluid waste.
- Call iReceptal Customer Service for docker decontamination procedures.
- Discarded electromedical equipment must not be disposed together with waste but must be collected separately to guarantee ecologically correct disposal to prevent dispersion of potential pollutants into the environment. Please hand in the device at the end of its useful life to the local collection and recycling point for electrical and electronic devices.

Failure to comply may cause environmental contamination or infection and result in personal injury.



Per the European Community (EC) Waste Electrical and Electronic Equipment (WEEE) Directive 2012/96/EC, product must be collected separately. DO NOT dispose of as unsorted municipal waste. Contact local distributor for disposal information. Ensure infected equipment is decontaminated prior to recycling.

Troubleshooting

NOTE: For service, contact your AMSINO sales representative or call AMSINO iReceptal Customer Service.

| PROBLEM | CAUSE | SOLUTION |
|--|--|---|
| Power switch does not illuminate in the ON position. | Power cord is not connected or is loosely connected. | Make sure the power cord is connected securely. |
| The rover will not dock or an error has occurred during the docking procedure. | The facility water valve is shut off. | Turn on the facility water valve. |
| | The docker is damaged. | Contact Customer Service. |
| Water inlet hose is leaking. | Water inlet hose connection is not secure. | Make sure the water inlet hose connection is secure. |
| | Water inlet hose is damaged. | Replace the water inlet hose. |
| Waste outlet hose is leaking. | Waste outlet hose connection is not secure. | Make sure the waste outlet hose connection is secure. |
| | Waste outlet hose is damaged. | Replace the waste outlet hose. |
| The docker does not dispense detergent during the cleaning cycle. | The canister of detergent is empty. | Add detergent |
| | If the problem persists, the docker detergent pump may be damaged. | Contact Customer Service. |
| Sporadic electrical interference is | Electrical noise is present. | Turn off all the electrical |

| | | |
|--------------|--|--|
| experienced. | | equipment not in use in the room. |
| | | Relocate the electrical equipment to maximize the distance between the equipment. Increase spatial distance. |
| | | Plug equipment into different outlets. |







Error Messages

NOTE: For error message information, see the instructions for use supplied with the rover.

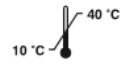
Specifications

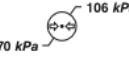
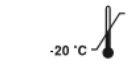
The Software (also incorporated into the device) has minimum requirements concerning IT security measures, including protection against unauthorised access, necessary to run the software as intended laid out in the instruction for use (IFU)

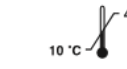
| | |
|---|--|
| Model: | |
| REF | iRD301 |
| Electrical Power Requirements: | 100V-240V~, 50/60 Hz, 3 A |
| Power inlet module | Power switch with 250V fuses on neutral and line connection |
| European Conformity: | CE |
| Product Safety Certification: | EN 60601-1:2006/A1:2013 Medical electrical equipment – Part 1: General requirements for basic safety and essential performance EN 60601-1-2:2015 Collateral Standard: Electromagnetic disturbances – Requirements and tests |
| Dimensions: | Width: 63.3cm Height: 86.3cm Depth: 43.7cm |
| Mode of Operation: | Continuous |
| Mass | 46kg—detergent empty 56kg—detergent full |
| Equipment Classification: | Class I Medical Electrical (ME) Equipment |
| Ingress Protection (IP): | IPX0 |
| Light Emitting Diode (LED) Classification (infrared communication windows): | WARNING: INVISIBLE LED RADIATION DO NOT VIEW DIRECTLY WITH OPTICAL INSTRUMENTS CLASS 1M LED PRODUCT — Viewing the laser output with certain optical instruments (for example, eye loupes, magnifiers and microscopes) within a distance of 100 mm may pose an eye hazard. |
| Ground Type: | Protective Earth (ground); when connected to facility power |
| Water Requirements: Pressure Range: Temperature Range: | 345 kPa to 827 kPa [50 to 120 psi] 4.4 to 43.3 °C [40 to 110 °F] NOTE: For optimal cleaning of the rover canisters, use 37.8 to 43.3 °C [100 to 110 °F]. |

| | | | |
|---|--|---|---|
| <p>Fitting Connection:</p> <p>Water Quality:</p> <p>Water Usage:</p> <p>Facility Backflow Prevention Device:</p> | <p>Facility source is equipped with a 3/4" Male (garden) Hose Thread (MHT) fitting and has a dedicated shutoff valve.</p> <p>Potable tap water</p> <p>Approximately 34 liters [9 gallons] per rinse cycle at default settings on standard cycle; water usage fluctuates due to selected cycle and facility flow.</p> <p>Refer to local plumbing codes to determine whether an external backflow prevention device is required.</p> | | |
| <p>Drainage Requirements: :</p> | <p>Floor drain or permanent service connection per local plumbing codes; 2.44 m [8 feet] connection distance (maximum)</p> | | |
| <p>Water Inlet Hose:</p> | <p>inner diameter: 25 cm [0.50 inch]</p> <p>length: 3m</p> | | |
| <p>Waste Outlet Hose:</p> | <p>inner diameter: 1.27 cm [0.50 inch]</p> <p>length: 3m</p> | | |
| <p>Waste Pump Outlet Flow:</p> | <p>23L/min</p> | | |
| <p>Environmental Conditions:</p> <p>Temperature Limitation</p> <p>Humidity Limitation</p> <p>Atmospheric Pressure Limitation:</p> | <p>Operation Transportation</p>    | <p>Storage and Transportation (before initial use)</p>    | <p>Storage and (after initial use)</p>    |

Electromagnetic Compatibility

Guidance and Manufacturer’s Declaration

Below cables information are provided for EMC reference.

| Cable | Max. cable length, Shielded/unshielded | | Number | Cable classification |
|---------------|---|------------|--------|-------------------------|
| | 3.0m | Unshielded | | |
| AC Power Line | 3.0m | Unshielded | 1 Set | AC Power |

Important information regarding Electro Magnetic Compatibility (EMC)

This electrical medical equipment needs special precautions regarding EMC and put into service according to the EMC information provided in the user manual; The equipment conforms to this IEC 60601-1-2:2014 standard for both immunity and emissions. Nevertheless, special precautions need to be observed:

- The equipment with no ESSENTIAL PERFORMANCE is intended used in Professional healthcare facility environment
- **WARNING:** Use of this equipment adjacent to or stacked with other equipment should be avoided because it could result in improper operation. If such use is necessary, this equipment and the other equipment should be observed to verify that they are operating normally”.
- The use of accessories, transducers and cables other than those specified or provided by the manufacturer of this equipment could result in increased electromagnetic emissions or decreased electromagnetic immunity of this equipment and result in improper operation.
- **WARNING:** Portable RF communications equipment (including peripherals such as antenna cables and external antennas) should be used no closer than 30 cm (12 inches) to any part of this product, including cables specified by the manufacturer. Otherwise, degradation of the performance of this equipment could result.”
- **WARNING:** If the use location is near (e.g. less than 1.5 km from) AM, FM or TV broadcast antennas, before using this equipment, it should be observed to verify that it is operating normally to assure that the equipment remains safe with regard to electromagnetic disturbances throughout the expected service life.

EMI Compliance Table (Table 1)

Table 1 - Emission

| Phenomenon | Compliance | Electromagnetic environment |
|---------------------|------------------------------|--|
| RF emissions | CISPR 11 Group 1, Class A | Professional healthcare facility environment |
| Harmonic distortion | IEC 61000-3-2 Class A | Professional healthcare facility environment |

| | | |
|----------------------------------|--------------------------|--|
| Voltage fluctuations and flicker | IEC 61000-3-3 Compliance | Professional healthcare facility environment |
|----------------------------------|--------------------------|--|

NOTE The EMISSIONS characteristics of this equipment make it suitable for use in industrial areas and hospitals (CISPR 11 class A). If it is used in a residential environment (for which CISPR 11 class B is normally required) this equipment might not offer adequate protection to radio-frequency communication services. The user might need to take mitigation measures, such as relocating or re-orienting the equipment.

EMS Compliance Table (Table 2-4)

Table 2 - Enclosure Port

| Phenomenon | Basic EMC standard | Immunity test levels |
|--|--------------------|--|
| | | Professional healthcare facility environment |
| Electrostatic Discharge | IEC 61000-4-2 | ±8 kV contact ±2kV, ±4kV, ±8kV, ±15kV air |
| Radiated RF EM field | IEC 61000-4-3 | 3V/m 80MHz-2.7GHz 80% AM at 1kHz |
| Proximity fields from RF wireless communications equipment | IEC 61000-4-3 | Refer to table 3 |
| Rated power frequency magnetic fields | IEC 61000-4-8 | 30A/m 50Hz or 60Hz |

Table 3 – Proximity fields from RF wireless communications equipment

| Test frequency (MHz) | Band (MHz) | Immunity test levels |
|----------------------|------------|--|
| | | Professional healthcare facility environment |
| 385 | 380-390 | Pulse modulation 18Hz, 27V/m |
| 450 | 430-470 | FM, ±5kHz deviation, 1kHz sine, 28V/m |
| 710 | 704-787 | Pulse modulation 217Hz, 9V/m |
| 745 | | |
| 780 | | |
| 810 | | |
| 870 | 800-960 | Pulse modulation 18Hz, 28V/m |
| 930 | | |
| 1720 | | |
| 1845 | 1700-1990 | Pulse modulation 217Hz, 28V/m |
| 1970 | | |
| 2450 | 2400-2570 | Pulse modulation 217Hz, 28V/m |
| 5240 | 5100-5800 | Pulse modulation 217Hz, 9V/m |
| 5500 | | |

Table 4 – Input a.c. power Port

| Phenomenon | Basic EMC standard | Immunity test levels |
|---|--------------------|---|
| | | Professional healthcare facility environment |
| Electrical fast transients/burst | IEC 61000-4-4 | ±2 kV 100kHz repetition frequency |
| Surges Line-to-line | IEC 61000-4-5 | ±0.5 kV, ±1 kV |
| Surges Line-to-ground | IEC 61000-4-5 | ±0.5 kV, ±1 kV, ±2 kV |
| Conducted disturbances induced by RF fields | IEC 61000-4-6 | 3V, 0.15MHz-80MHz 6V in ISM bands between 0.15MHz and 80MHz 80%AM at 1kHz |
| Voltage dips | IEC 61000-4-11 | 0% U_T ; 0.5 cycle At 0°, 45°, 90°, 135°, 180°, 225°, 270° and 315° |
| | | 0% U_T ; 1 cycle and 70% U_T ; 25/30 cycles Single phase: at 0° |
| Voltage interruptions | IEC 61000-4-11 | 0% U_T , 250/300 cycles |