



Advancing Healthcare Worldwide®

iReceptal Digital Surgical Suction System

Installation, Operation and Maintenance Guide

100~120 VAC Rover

REF iRR301

220~240 VAC Rover

REF iRR302

Instructions For Use

R_x ONLY

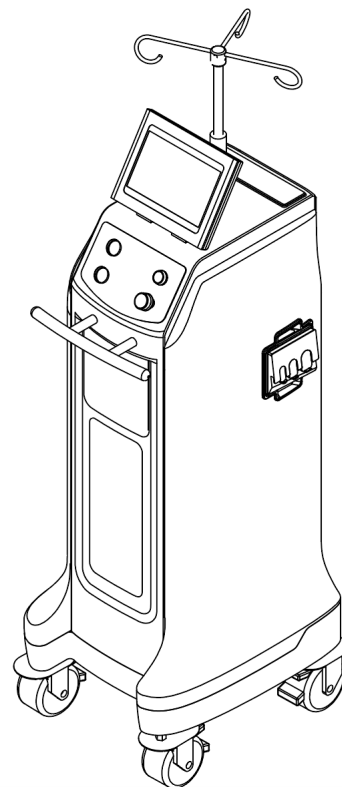

WARNING:

HIGH SUCTION DEVICE

Only trained and experienced healthcare professionals may use this equipment.



DO NOT connect directly to chest tubes.



ALWAYS use the minimum suction setting required to achieve the desired clinical outcome.



DO NOT connect to closed wound drains.



NOT FOR USE as a suction source for organ stabilizer/positioner or patient positioner devices.



DO NOT connect directly to tracheal tubes.



NOT FOR USE as a suction source for intermittent suction applications.

**FAILURE TO COMPLY COULD RESULT
IN SERIOUS INJURY OR DEATH.**

DO NOT remove any safety card from the equipment.

For more information, including safety information, or in-service training, contact your AMSINO sales representative or call iReceptal Customer

Service

Contents

Introduction	5
Conventions	5
Contact Information	5
Indications For Use.....	5
Contraindications For Use	5
Intended patient	5
For Use With.....	5
Accessories	6
System Overview	6
User/Patient Safety.....	8
General.....	8
Low Suction	9
High Suction	9
Electrical Safety	9
Environmental/Biological	10
Features	12
Graphical user interface.....	14
System On	14
High suction device warning view.....	15
Patient information input view	15
Manifold installation view	16
Main view	16
Settings View	19
Data View.....	20
Help View	21
Wash Cycle View	23
Popup View.....	23
Definitions	24
Suction Setting Colors.....	24
Notification Message	25
Audible Event Indicators	25
Symbols.....	25
Instructions.....	27
Before First Use	27
To Unpack the Rover.....	27
To Initially Dock the Rover.....	28
To Test the Rover	28
1. To Connect Power	28
2. To Test Fluid Suction	28
3. To Test Smoke Evacuation	29
4. To Test the IV Pole.....	29
5. To Test the Chamber access doors.....	30

6. To Test the Chamber lights	30
To Adjust the Rover Settings.....	30
Before the Procedure	31
To Setup the Rover.....	31
1. To Connect Power	31
2. To Prepare For Fluid Suction.....	32
3. To Prepare For Smoke Evacuation.....	33
4. To Use the IV Pole.....	33
5. To Use the Chamber lights.....	34
During the Procedure	34
To Operate the Rover.....	34
1. To Control Fluid Suction	35
2. To Control Smoke Evacuation	36
3. To Adjust the IV Pole.....	36
4. To Open or Close the Chamber access doors	36
5. To Turn On or Turn Off the Chamber lights.....	37
6. To Manage Full Canister	37
After the Procedure.....	38
To Shutdown the Rover	38
1. To Remove Fluid Suction Components.....	38
2. To Remove Smoke Evacuation Components.....	39
3. To Remove IV Pole Components.....	40
4. To Remove Power	40
5. To Prepare for Relocation	41
6. To Relocate the Rover	41
To Dock the Rover	42
1. To Prepare the Docker.....	42
2. To Perform a Wash Cycle	42
Inspection and Cleaning Maintenance	44
To Wipe Down the Rover.....	46
Storage and Handling	46
Disposal/Recycle	47
Troubleshooting	47
Error Messages.....	50
Specifications	51
Electromagnetic Compatibility.....	54
Appendix	57
To Use Auxiliary Suction Ports (optional).....	57

Introduction

This Instructions For Use manual is the most comprehensive source of information for your product. Keep and consult this reference manual during the life of the product.

Conventions

The following conventions are used in this manual:

WARNING: A warning highlights a safety-related issue. ALWAYS comply with this information to prevent patient or healthcare staff injury.

CAUTION: A caution highlights a product reliability issue. ALWAYS comply with this information to prevent product damage.

NOTE: A note supplements and/or clarifies procedural information.

Contact Information

For additional information, including safety information, or in-service training, contact your AMSINO sales representative or call AMSINO iReceptal Customer Service.

Indications For Use

The iReceptal Digital Surgical Suction System Rover (rover) is used to suction and collect fluid waste and evacuate surgical smoke from a surgical site in an operating room.

Contraindications For Use

The iReceptal Digital Surgical Suction System Rover is contraindicated against:

- Connection directly to chest tubes.
- Connection to closed wound drainage systems.

Intended patient

The general patient population is anyone excluding newborn subject to general surgeries where the device can be used.

For Use With

The following components are required to be used with the equipment described in this manual:

Description	REF
iReceptal 3 Manifold	iRM300
iReceptal 3 Manifold with disinfectant	iRM301
Smoke Evacuator ULPA filter	iRF300

NOTE: Smoke Evacuator tubing and other accessories are also required for a complete system. These

components may not be sold by AMSINO. See the Contact Information section for more information.

Accessories

This section describes system components that may be ordered to replace original equipment that is damaged, worn, or must be replaced. This section may also contain optional components used with the system.

The following AMSINO-approved accessories are sold separately:

Description	REF
iReceptal 3 Docking Detergent	iRC003
iReceptal 3 Manifold	iRM300-01
Smoke Evacuator ULPA Filter	iRF300-01
Fluid suction tubing	iRA104-01
Pneumatic Footswitch	iRA100-01
Power Cord (US)	iRA101-01
Power Cord (UK)	iRA102-01
Power Cord (EU)	iRA103-01

NOTE: For a complete list of accessory information, contact your AMSINO sales representative or call AMSINO iReceptal Digital Surgical Suction System Customer Service.

System Overview

The iReceptal Digital Surgical Suction System Rover (rover) is a mobile unit used to suction and collect fluid waste and surgical smoke from a surgical site in an operating room. The rover also has a height-adjustable, powered IV pole.

During collection, fluid waste is removed from the surgical site through suction tubing connected to inlet ports of manifold installed in the rover. The fluid waste is collected in the canister of the rover (Figure 1). The canister design allows suction setting and fluid volume measurement capability. The vacuum pump exhaust is filtered.

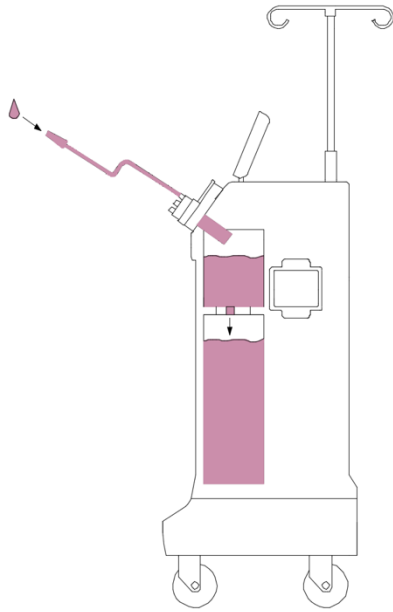

Figure 1 To collect Fluid Waste

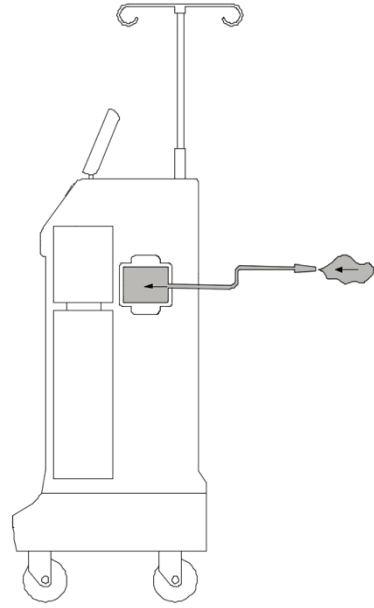

Figure 2 To Evacuate Surgical smoke

Surgical smoke may also be evacuated from the surgical site through smoke tubing connected to the smoke evacuator filter installed in the rover. The surgical smoke is filtered inside the rover (Figure 2).

After collection, the rover is relocated and mated to the iReceptal Digital Surgical Suction System Docking Station (docked). Once the rover is connected to the dock, the emptying of the fluid waste and cleaning of the upper chamber and Lower Chamber of the canister occurs automatically (Figure 3).

The upper chamber and Lower Chamber of the rover canister are rinsed with clean water and iReceptal Digital Surgical Suction System Docking Detergent REF iRC003 to clean the canister of any residual fluid waste (Figure 4).

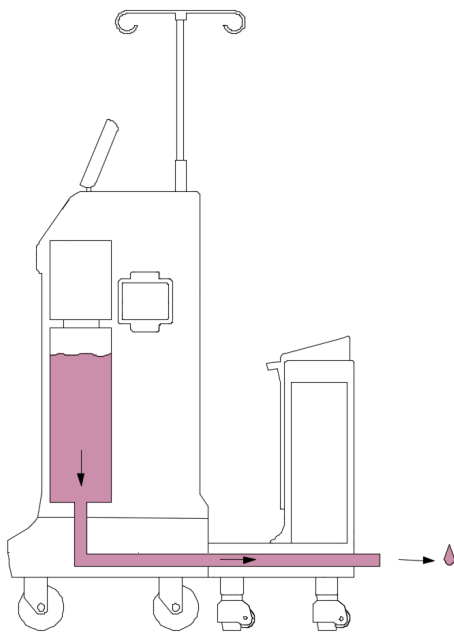

Figure 3 To Empty the Canister

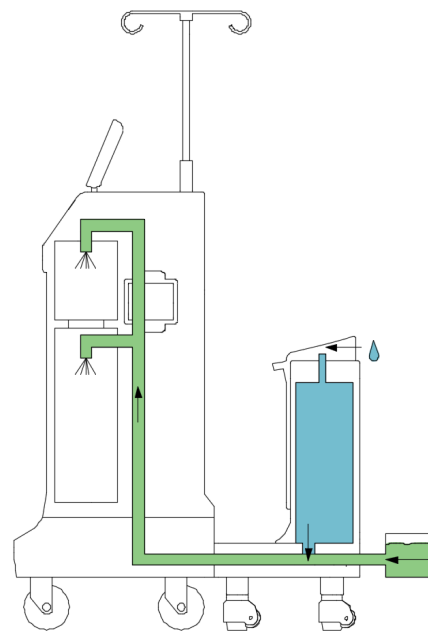

Figure 4 To Clean the Canister

User/Patient Safety

WARNINGS:

General

- Before using any system component, or any component compatible with this system, read and understand the instructions. Pay particular attention to WARNING information. Become familiar with the system components prior to use.
- Only trained and experienced healthcare professionals may use this equipment.
- Healthcare professionals should be thoroughly familiar with the instructions for use, handling characteristics, and the indicated and intended uses of this equipment. Contact your AMSINO sales representative or AMSINO iReceptal Digital Surgical Suction System Customer Service for in-service training.
- The healthcare professional performing any procedure is responsible for determining the appropriateness of this equipment and the specific technique used for each patient. AMSINO, as a manufacturer, does not recommend surgical procedure or technique.
- DO NOT disassemble, modify, service, or repair any system component or accessory, unless otherwise specified. Call AMSINO iReceptal Digital Surgical Suction System Customer Service.
- Upon initial receipt and before each use, inspect each component for damage. DO NOT use any equipment if damage is apparent or the inspection criteria are not met. See the Inspection and Maintenance section for inspection criteria.
- ALWAYS operate the equipment within the specified environmental condition values. See the Specifications section.
- The canister scale and fluid volume display are not diagnostic tools. DO NOT use the scale or fluid volume display to determine the amount of fluid lost from or retained by the patient.
- DO NOT cover the device user interface with drapes or other objects. Make sure the user interface can be clearly seen.
- TIPPING HAZARD — DO NOT lean on the rover. Please pull the handle when cross the step, do not push the rover.
- MANUFACTURER will provide circuit diagrams, component part lists, descriptions, calibration instructions to assist to SERVICE PERSONNEL in parts repair.
- Do not use iReceptal Digital Surgical Suction System in the presence of magnetic resonance imaging (MRI) devices.
- The use of ACCESSORIES other than those specified by AMSINO or sold by AMSINO as replacement parts for internal components, may result in increased emissions or decreased immunity of the iReceptal Digital Surgical Suction System.

Low Suction

- LOW SUCTION HAZARD

NOT FOR USE as a suction source for the following applications:

- Organ stabilizer/positioner devices
- Patient positioner devices

Death or serious injury can result from fluctuating suction levels.

High Suction

- HIGH SUCTION DEVICE [MAX = -528 mmHg/-70kPa]

- The effectiveness of aspiration is dependent upon the intensity of the vacuum applied.
- ALWAYS use the minimum suction setting required to achieve the desired clinical outcome.
- ALWAYS follow your institution's guidelines for suction limits.
- DO NOT connect directly to chest tubes.
- DO NOT connect to closed wound drains.
- DO NOT connect directly to tracheal tubes.
- NOT FOR USE as a suction source for intermittent suction applications.

Death or serious injury can result from improper suction levels.

- The suction setting may only be adjusted by the SUCTION SETTING on the touch display. Interruption and restoration of rover power, whether accidental or intentional, does not reset the suction setting to zero.

Electrical Safety

- Use only AMSINO-approved system components and accessories, unless otherwise specified. Using other electronic components and accessories may result in increased electromagnetic emissions or decreased electromagnetic immunity of the system.
- Take special precautions regarding electromagnetic compatibility (EMC) when using medical electrical equipment like this system. Install and place this system into service according to the EMC information contained in this manual. See the Specifications section
- This equipment utilizes mobile RF communications equipment that can affect medical electrical equipment.
- Please take attention that changes or modification not expressly approved by the party responsible for compliance could void the user's authority to operate the equipment.
- This device complies with Part 15 of the FCC Rules. Operation is subject to the following two conditions:
(1) This device may not cause harmful interference, and
(2) This device must accept any interference received, including interference that may cause undesired operation.
- This device complies with Industry Canada licence-exempt RSS standard(s). Operation is subject to the

following two conditions:

(1) this device may not cause interference, and

(2) this device must accept any interference, including interference that may cause undesired operation of the device.

- Le présent appareil est conforme aux CNR d'Industrie Canada applicables aux appareils radioexempts de licence. L'exploitation est autorisée aux deux conditions suivantes :
- (1) l'appareil ne doit pas produire de brouillage, et
- (2) l'utilisateur de l'appareil doit accepter tout brouillage radioélectrique subi, même si le brouillage est susceptible d'en compromettre le fonctionnement.
- This equipment complies with FCC/IC RSS-102 radiation exposure limits set forth for an uncontrolled environment. This equipment should be installed and operated with minimum distance 20cm between the radiator & your body.
- ce matériel est conforme aux limites de dose d'exposition aux rayonnements, FCC / CNR-102 énoncée dans un autre environnement.cette equipment devrait être installé et exploité avec distance minimale de 20 entre le radiateur et votre corps.
- Under Industry Canada regulations, this radio transmitter may only operate using an antenna of a type and maximum (or lesser) gain approved for the transmitter by Industry Canada. To reduce potential radio interference to other users, the antenna type and its gain should be so chosen that the equivalent isotropically radiated power (e.i.r.p.) is not more than that necessary for successful communication.
- Conformément à la réglementation d'Industrie Canada, le présent émetteur radio peut fonctionner avec une antenne d'un type et d'un gain maximal (ou inférieur) approuvé pour l'émetteur par Industrie Canada. Dans le but de réduire les risques de brouillage radioélectrique à l'intention des autres utilisateurs, il faut choisir le type d'antenne et son gain de sorte que la puissance isotrope rayonnée équivalente (p.i.r.e.) ne dépasse pas l'intensité nécessaire à l'établissement d'une communication satisfaisante.
- **ELECTRICAL SHOCK HAZARD**
 - ALWAYS connect this equipment to a hospital-grade, facility power receptacle with protective earth (ground).
 - Do not position Rover so that disconnecting the device is difficult.
 - DO NOT touch or make contact with the rover and patient simultaneously.

Failure to comply may cause electrical shock and result in patient or healthcare staff injury.

Environmental/Biological

- **FIRE HAZARD – DO NOT** use this equipment in areas in which flammable anesthetics or flammable agents are mixed with air, oxygen or nitrous oxide. Failure to comply may cause a fire and result in burn injury or property damage.
- **BLOODBORNE PATHOGEN HAZARD**
 - The Bloodborne Pathogens Standard provided by the United States Occupational Safety and Health Association (US OSHA 29 CFR 1910.1030) requires those with employees having occupational exposure to potentially infectious materials to establish a written Exposure Control Plan. The Exposure Control Plan is designed to eliminate or minimize employee exposure through use of personal protective equipment (PPE), appropriate vaccinations (e.g. hepatitis B), and other control measures.

- ALWAYS wear PPE when operating or handling this equipment.
- ALWAYS follow local regulations regarding proper handling and disposal of biohazard waste.

Failure to comply may cause infection and result in healthcare staff injury.

- ALWAYS clean the equipment as indicated upon initial receipt and before each use. DO NOT place the rover within the sterile field. Failure to comply may cause infection and result in patient or healthcare staff injury.
- CONTAMINATION HAZARD
 - DO NOT collect fluids from patients being treated with radioisotopes or hazardous chemical agents.
 - ALWAYS follow local regulations for safe handling, recycling, and disposal of biohazard fluid waste and equipment. See Disposal/Recycle section.

Failure to comply may cause environmental contamination and result in injury.

- The manifold is for SINGLE PATIENT USE ONLY. DO NOT sterilize or reuse. DO NOT reuse, reprocess, or repackage a single use device. A single use device is intended for a single use only. The single use device may not withstand chemical, chemical vapor, or high temperature sterilization reprocessing. Design features may make cleaning difficult. Reuse may create a serious risk of contamination and may compromise the structural integrity of the device resulting in operational failure. Critical product information may be lost if the device is repackaged. Failure to comply may lead to infection or cross-infection and result in patient or healthcare staff injury.
- ALWAYS make sure rover power is ON when collecting fluid waste. The rover can only detect full canister if the rover is ON. If the rover is OFF, biohazard waste leakage or loss of suction can occur.

Features

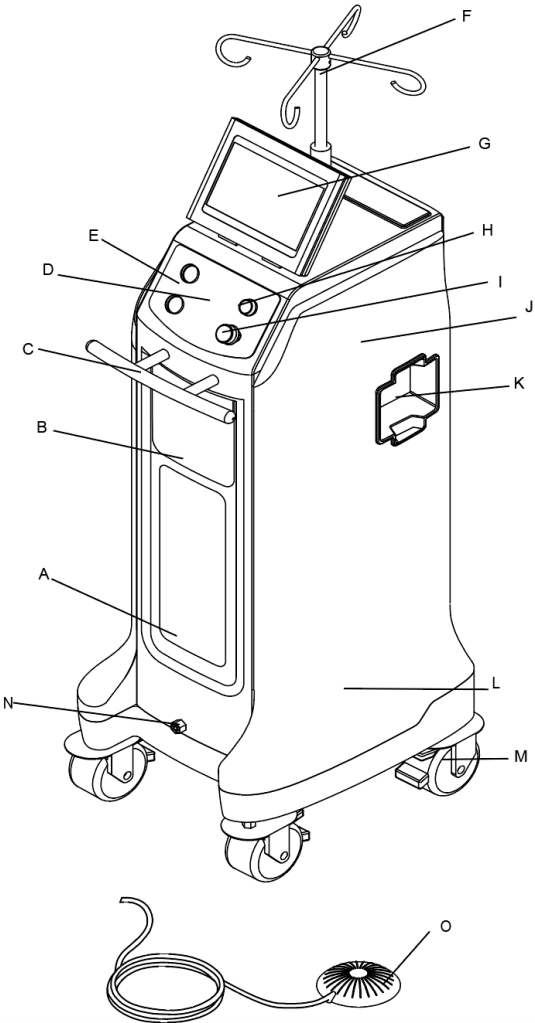

Figure 5 Rover Front View

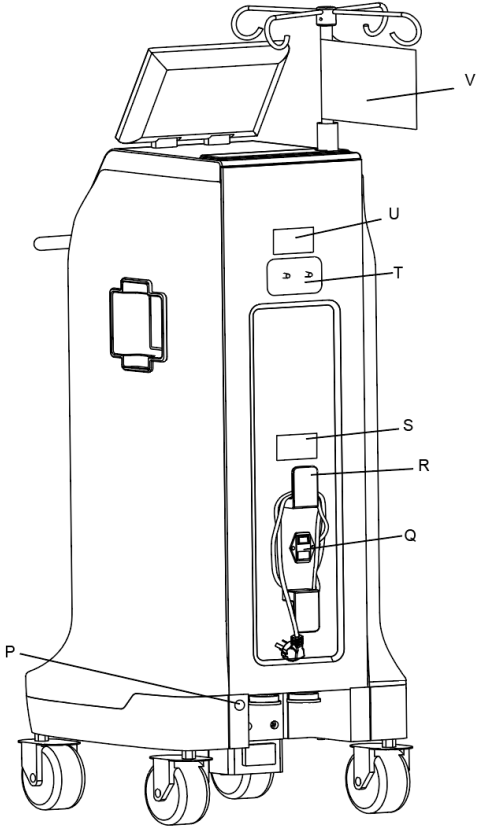
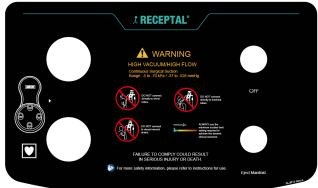



Figure 6 Rover Back View

A	22L (22-liter) Lower Chamber of Canister – Allows for the containment of liquids. The 22-liter Lower Chamber receives fluid through the upper chamber during the collection of fluid waste. The Lower Chamber contains a fluid level sensor to provide input to the LCD display.
B	4.5L (4.5-liter) upper chamber of Canister – Allows for the collection and containment of liquids. The 4.5-liter upper chamber receives fluid through an installed manifold during the collection of fluid waste. The upper chamber contains a light to provide a good view, also contains a fluid level sensor to provide input to the LCD display.
C	Handle – Allows for relocation and positioning of the rover.
D	High Suction Device WARNING Label – 
E	Manifold socket – Allows installation of a disposable manifold into the canister. The socket can be closed when a manifold is removed. Socket door prevents fluid leakage during transport and docking

	and prevents foreign objects from entering the canister.
F	Powered IV Pole – This motor-powered IV pole is capable of holding four three-liter [3000 mL] IV bags, one bag per hook.
G	LCD Display – Provides the operation of rover. Provides visual display of the fluid volume values of each chamber. Display brightness may also be adjusted. See the To Adjust the Rover Settings section. Provides suction values for the canister, system status and error messages.
H	Suction Off/Stop Docking Button– Push the button to stop suction when suction on. Push the button to stop docking when docking.
I	Pop the manifold out Button – Push the button to pop the manifold out.
J	Speaker (not shown) – Located inside the rover, provides audible event indicators. See the Audible Event Indicators table.
K	Smoke Evacuator ULPA Filter Compartment – Allows for the installation and removal of a disposable smoke evacuator filter with an Ultra Low Penetrating Air (ULPA) efficiency rating.
L	Single Vacuum Pump (not shown) – Creates suction for the canister.
M	Casters (four) – Four swivel casters allow the rover its mobility. The four casters have locks to prevent inadvertent movement during operation.
N	Footswitch Jack - Allow connection to a pneumatic footswitch. When the footswitch is plugged in, the fan may be turned on or off by depressing the footswitch pedal once for each operation.
O	Footswitch Pedal – Allows turn on or off the Fan by depressing the Footswitch pedal once for each operation.
P	Infrared Communication Window – Allows data transfer between the docker and rover. Data transfer is necessary during the docking procedure.
Q	Power Cord Receptacle/Switch – Connect facility power to the receptacle using the rover power cord. Tap the toggle switch to apply or remove facility power. See the Definitions section for ON and OFF power symbol definitions.
R	Power Cord Bracket/Cord – Store the power cord on the bracket. Use the power cord to connect the rover to facility power.
S	Specification Label –
T	Auxiliary Suction Ports (optional) – Allow connection to a hospital wall suction regulator if an alternate suction source is required. See the Appendix, To Use Auxiliary Suction Ports (optional) section.
U	Auxiliary Suction Ports Label – 
V	Quick Reference Cards – Allows for quick access to specific High suction device information and Tipping Hazard WARNING.

Graphical user interface

iReceptal Digital Surgical Suction System Rover display is a touch screen, where you slide (1) or tap (2) the icons and soft BUTTONs gently with your fingertip to select them.

- 1. Tapping soft BUTTON

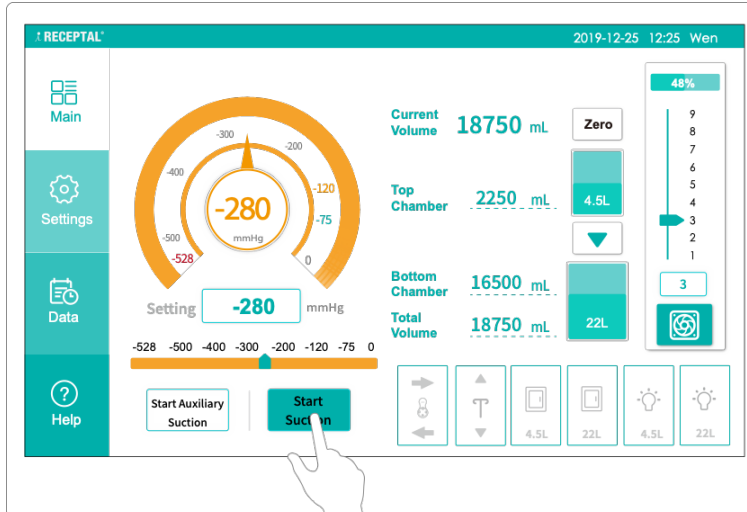

- 2. Sliding soft BUTTON

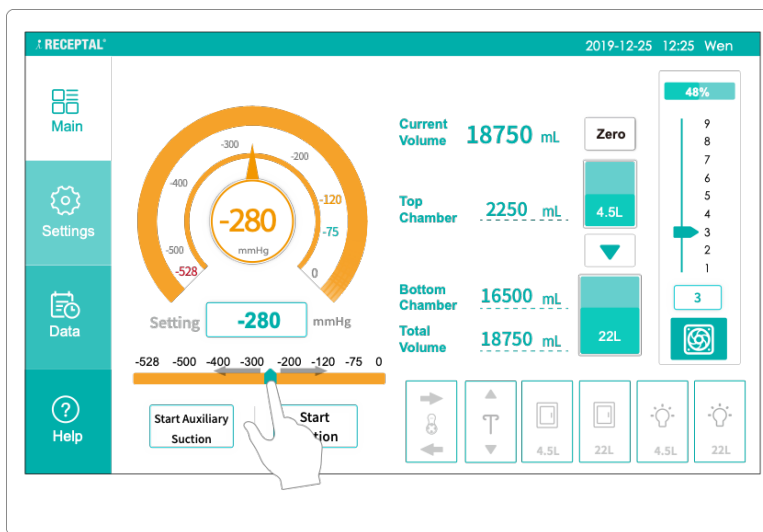

Touch screen colors

When a screen item is interactive, it is displayed in green. Soft BUTTONs have a green outline and icons with available functions appear green.

Disabled items or inactive items appear grey.

System On

The system will present a “welcome screen” automatically after connected to the facility power with the switch turned “ON”.



High suction device warning view

Without any operation, the “high suction device warning view” will pop up.

Read the content of the warning information, tap the "Confirm" button to control the user interaction interface.

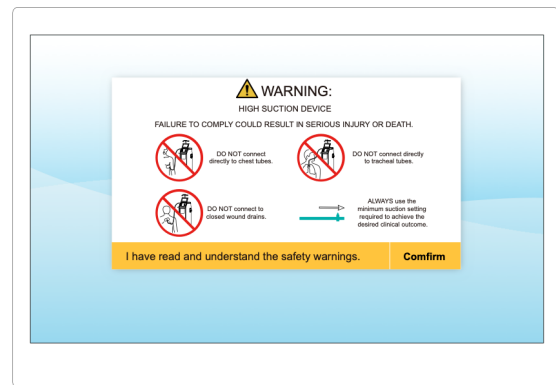
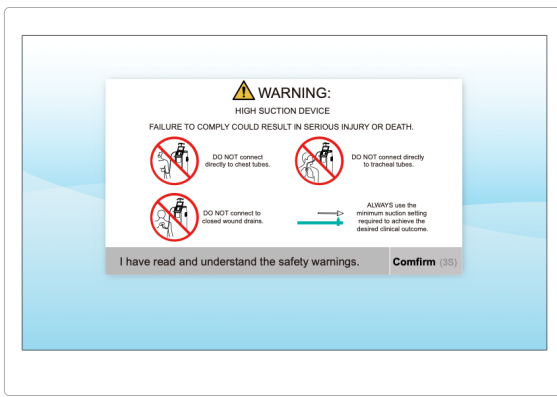

Patient information input view

After obtaining the control user interaction interface, please follow the requirements to input patient information, you can skip it by tapping the "skip" button below.

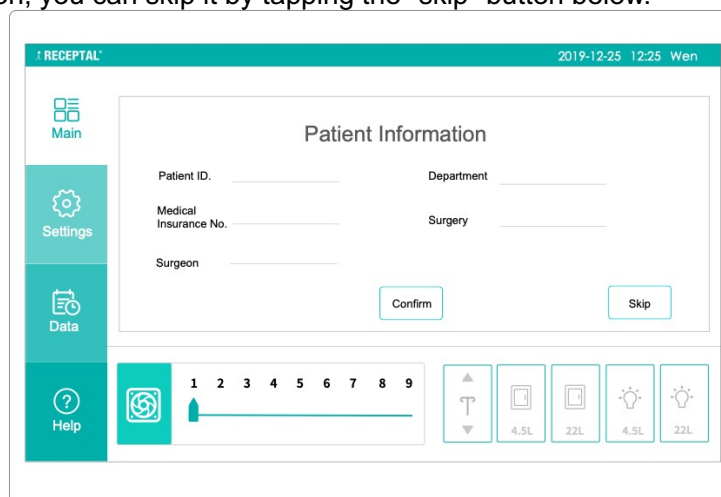

1. The left section contains four soft BUTTONS for switching the view of the interface: Main, Settings, Data, and Help. For the definitions of these soft BUTTONS, please refer to the “Main View” section.
2. The middle section allows for Creating New Patient information.

3. The bottom section allows the control of smoke evacuator and the adjustment of the smoke evacuator flow rates and contains the IV pole, the Upper and Lower Chamber windows, and the Upper and Lower Chamber lights soft BUTTONS. For the definitions of these soft BUTTONS, please refer to the Main View section.

Manifold installation view

Please follow the requirements to install the manifold. For help information about installation, see the "Help View" section.

Install a new disposable manifold into the manifold socket. Make sure the manifold is fully inserted and locked into place. See the instructions for use supplied with the manifold for more information

The Manifold installation view is divided into three functional sections:

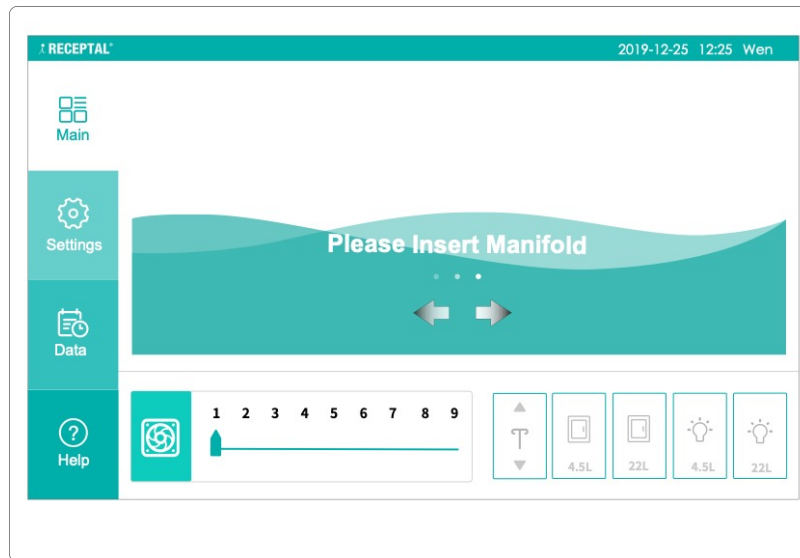

1. The left section contains four soft BUTTONS for switching the view of the interface: Main, Settings, Data, and Help. For the definitions of these soft BUTTONS, please refer to the "Main View" section.
2. The middle section allows for opening and closing the manifold socket.
3. The bottom section allows the control of smoke evacuator and the adjustment of the smoke evacuator flow rates and contains the IV pole, the Upper and Lower Chamber windows, and the Upper and Lower Chamber lights soft BUTTONS. For the definitions of these soft BUTTONS, please refer to the Main View Section.

Main view

The main view is divided into five functional sections:

1. The left section (1) contains four soft BUTTONS for switching the view of the interface: Main, Settings, Data, and Help.
2. The middle sections (2) (3) allow start the pump and the adjustment of the suction setting level, also, right the suction regulator shows a graphical presentation of the upper chamber and Lower Chamber of the canister status and collected fluid.

- The right section (4) allows the control of smoke evacuator and the adjustment of the smoke evacuator flow rates.
- The bottom section (5) from the left to the right is manifold socket door, IV pole, Upper and Lower Chamber windows, and Upper and Lower Chamber lights soft BUTTONS.

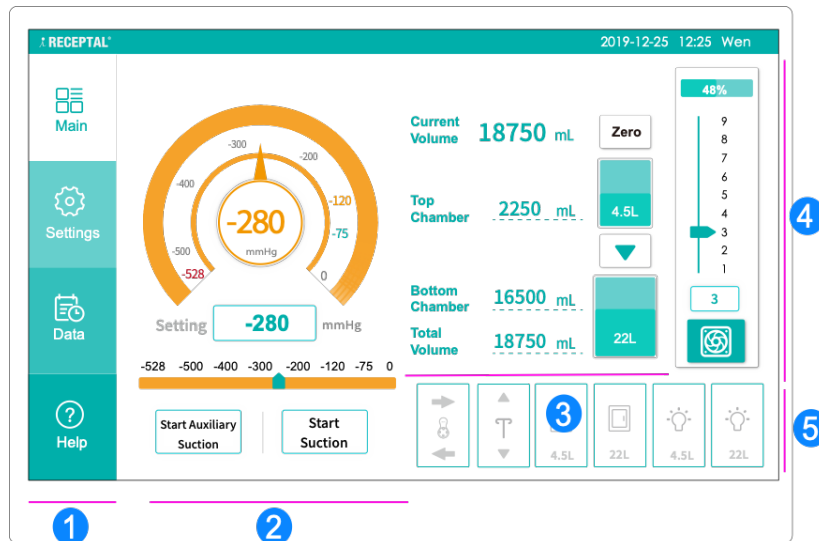

Left section



The Main BUTTON opens the Main view. For more information, see “Main view”.



The Settings BUTTON opens the Settings view. For more information, see “Settings view”.



The Data BUTTON opens the Data view. For more information, see “Data view”.



The Help BUTTON opens the Help view. For more information, see “Help view”.

Middle section



Notification Message area – The area displays Notifications//Warnings. The area flashes "High vacuum in operation" as the negative Suction Setting value is in the high negative pressure range. when the canister is full, this area flashes "Canister full, Dock the Rover".



Suction Level Value Area – Provides the suction level value for the canister. The actual negative pressure value is displayed in the middle, indicating the current suction level actually present in the canister. Actual values may fluctuate and may be significantly lower than the set value.

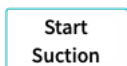

Start Suction BUTTON –Tap the Start Suction BUTTON to start the vacuum pump. When the manifold has been used or the canister is full, etc., the negative pressure pump cannot be turned on. For more information, see the "Troubleshooting" section.

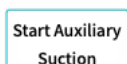

Start Auxiliary Suction BUTTON—Tap the BUTTON to turn on the

Setting **-280** mmHg

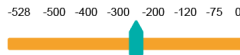

Current Volume **18750** mL

Zero

Top Chamber	2250 mL	4.5L
Bottom Chamber	16500 mL	
Total Volume	18750 mL	22L



Right section

48%



1



Auxiliary suction when use the auxiliary suction ports.

Suction Level Setting BUTTON – Tap the BUTTON to input the pressure value through the pop-up numeric BUTTON board. The Suction Level Setting value will be displayed in this position. The Suction Level Setting should not exceed the pressure range specified by this equipment.

Suction Level Setting Bar – Tap any position on the Setting bar or slide the point to adjust the Suction Level Setting value.

Note: When the Suction Level Setting is in the high negative pressure range, "High vacuum in operation" voice message will be heard with Message area flashes the relative notification.

Current volume area – Displays the current total volume since last reset or since start the suction.

Zero BUTTON – Reset the current volume to zero by tapping it.

Fluid Level Display Area – The volume of fluid is displayed by numbers and graphics. The total volume of the Upper chamber is 4.5L and the total volume of the Lower Chamber is 22L. As the fluid increases, the figures and volume increase automatically.

Note: When the Lower Chamber is full, "Lower chamber Full" voice message will be heard with Message area flashes the relative notification. When the Canister is full, "Canister full, please dock the Rover " voice message will be heard with Message area flashes the relative notification.

Empty 4.5L upper chamber BUTTON – Opens the valve between the upper chamber and the Lower Chamber of the canister and transfers the contents of the 4.5-liter chamber into the 22-liter chamber, the valve will be closed automatically when the 4.5-liter chamber is empty.

Smoke Filter Indicator – Displays the smoke filter's remaining usable time as a percentage.

Note: When the maximum filter is consumed, "Smoke Filter about to its useful life" voice message will be heard with Message area flashes the relative notification.

Smoke Evacuator Power Setting bar – Tap any position on the Setting bar or slide the point to adjust the Smoke evacuator power.

Smoke Evacuator Power Setting BUTTON – Tap the BUTTON to input the smoke evacuator power through the pop-up numeric BUTTON board. The smoke evacuator power value will be displayed in this position.

Smoke Evacuator BUTTON – Tap the smoke evacuator icon to turn on or turn off the smoke evacuator. When the smoke filter expired or installed

incorrectly, etc., the smoke evacuator cannot be turned on. For more information, see the "Troubleshooting" section.

Bottom section



Manifold socket door BUTTON – Tap the right direction icon to open the manifold socket door, tap the left direction icon to close the manifold socket door.



IV Pole BUTTON - Tap and hold the UP or DOWN arrow BUTTON to raise or lower the height of the IV pole, respectively.



Upper/Lower Chamber Access Door BUTTON- Tap and hold the upper or lower window BUTTON to open or close the window of the chamber, respectively.

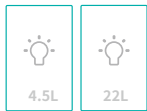

Upper/Lower Chamber Light BUTTON- Tap the upper or lower Chamber Light BUTTON to turn on or turn off the Upper/Lower Chamber Light respectively.

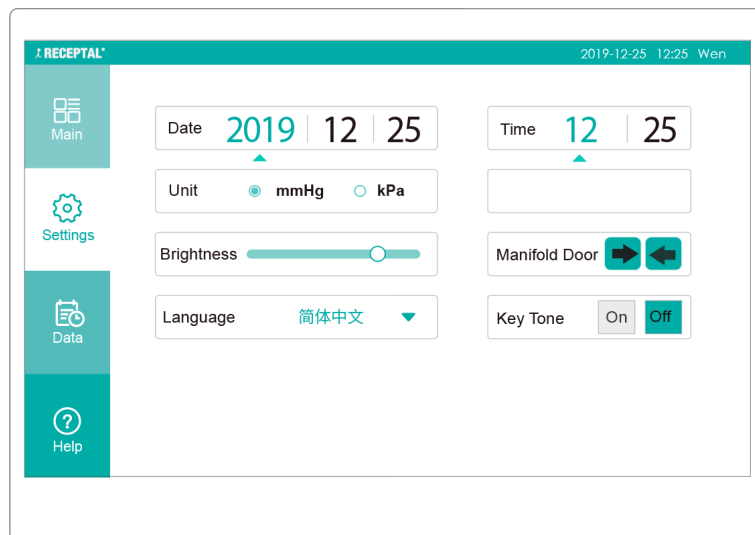

Settings View

Tap the Settings BUTTON to access the setup view with options for custom settings.



System Setting Options

Menu	Settings	Function	Default
Date	YYYY-MM-DD	Tap the year box. The selected box is highlighted. Adjust the year with the arrow BUTTONs. The arrow BUTTONs only affect the	2020-01-01

		selected box.	
Time	hh : mm	Tap the hours box. The selected box is highlighted. Adjust the hours with the arrow BUTTONs. The arrow BUTTONs only affect the selected box.	00: 00
Suction unit	kPa, mmHg	Tap the BUTTON to select the suction unit shown on the screen.	mmHg
Display Brightness		Tap or slide the display brightness level gauge to adjust the display brightness	
Language	简体中文, English	Tap the arrow BUTTON to select the language of the user interface. Note: To activate the language selection a device restart is required.	English
Manifold Socket Door		Tap the right direction icon to open the manifold socket, tap and hold the left direction icon to close the manifold socket	-----
BUTTON Tone	on, off	Tap the Audio BUTTON to switch fluid audible indicators ON and OFF.	On

Data View

Tap the Data BUTTON to access the Data view. The device automatically saves a summary of the last 1000 operations. There are two data sheets in this data view, one for fluid suction operations and another one for docking operations, change the view by tapping the Data BUTTON.

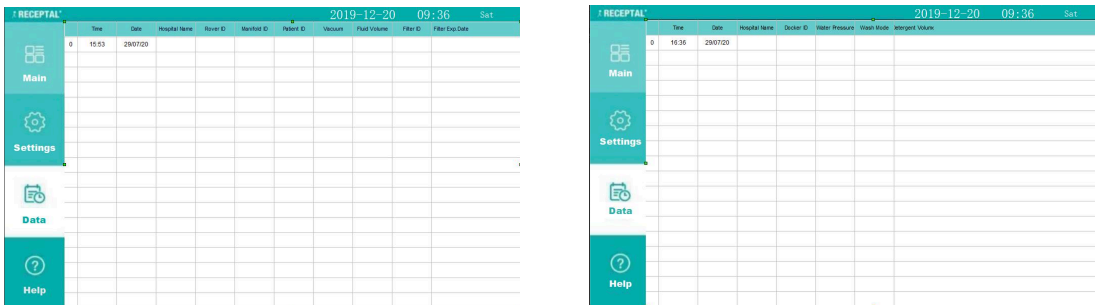

The following data is saved for every fluid suction operation:

Time	Date	Hospital name	Rover ID	Manifold ID	Patient ID	Vacuum	Fluid Volume	Filter ID	Filter Exp. life

--	--	--	--	--	--	--	--	--	--

The following data is saved for every docking operation:

Time	Date	Hospital name	Docker ID	Manifold ID	Water pressure	Washing cycle	Detergent volume

Help View

Tap the “Help” BUTTON to access the Help view with the operation instructions and the troubleshooting.

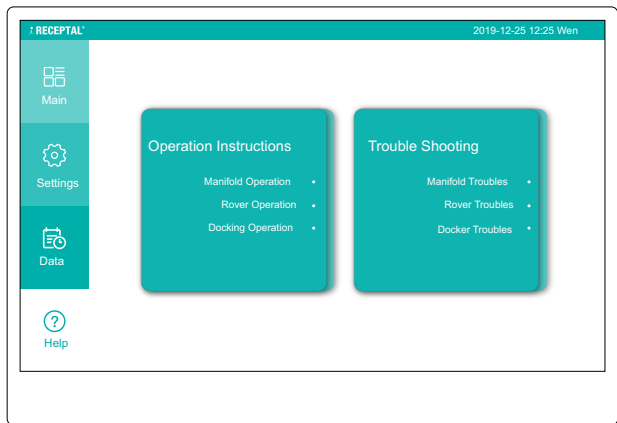

The Help view is divided into two sections:

1. The left section is the operation instructions, including Manifold, Rover Operation, and Docking Drain and Clean.
2. The right section is the Troubleshooting, including Manifold Troubles, Rover Troubles, and Docker Troubles.

Operation Instructions

- Manifold Operation** Manifold Operation instruction BUTTON-Tap the BUTTON opens the Manifold related operation instructions. For more information, see “Operation Instructions table”.
- Rover Operation** Rover Operation instruction BUTTON-Tap the BUTTON opens the Smoke filter related operation instructions. For more information, see “Operation Instructions table”.
- Docking Operation** Docking operation instruction BUTTON - Tap the BUTTON opens the Docking related operation instructions. For more information, see “Operation Instructions table”.

Troubleshooting

Manifold Troubles

Manifold related troubleshooting BUTTON-Tap the BUTTON opens the Manifold related troubleshooting. For more information, see “Troubleshooting table”.

Rover Troubles



Rover related troubleshooting BUTTON-Tap the BUTTON opens the Rover related troubleshooting. For more information, see “Troubleshooting table”.

Docker Troubles

Docking related troubleshooting BUTTON-Tap the BUTTON opens the Docking related troubleshooting. For more information, see “Troubleshooting table”.

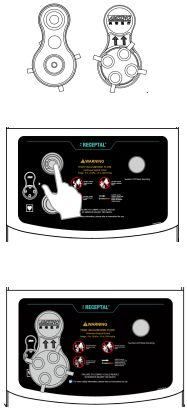
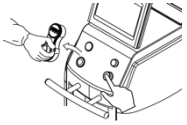
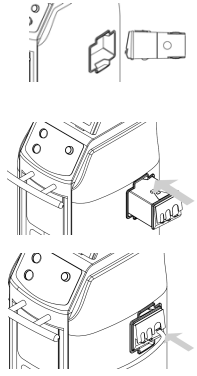
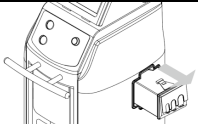
Operation Instructions table

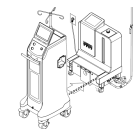
Operation Instructions		Content
Manifold operation instruction	Manifold installation	<ol style="list-style-type: none"> 1. Verify Orientation of the Manifold 2. Make sure the manifold door is open 3. Insert the Manifold and Make sure the Manifold is inserted completely in place 
	Manifold uninstallation	<ol style="list-style-type: none"> 1. Eject Manifold To take out the manifold, please hold the manifold with one hand and push the “Eject Manifold” button with the other hand. 
Rover operation instruction	Smoke filter installation	<ol style="list-style-type: none"> 1. Please use new ULPA Filter with Encrypted RFID chips 2. Insert the ULPA Filter 3. Connect the smoke suction tube to the port with correct dimension 
	Smoke filter uninstallation	<ol style="list-style-type: none"> 4. Change the ULPA filter Take out the ULPA filter from the ULPA compartment 

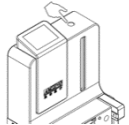
Docking operation instruction	Docking	<ol style="list-style-type: none"> 1. Dock the Rover to Docker 2. Docker Operation Instructions 	 
	Add detergent	<ol style="list-style-type: none"> 1. Add detergent 	

Wash Cycle View

As the rover and docker attached together, the Wash Cycle View will display automatically.

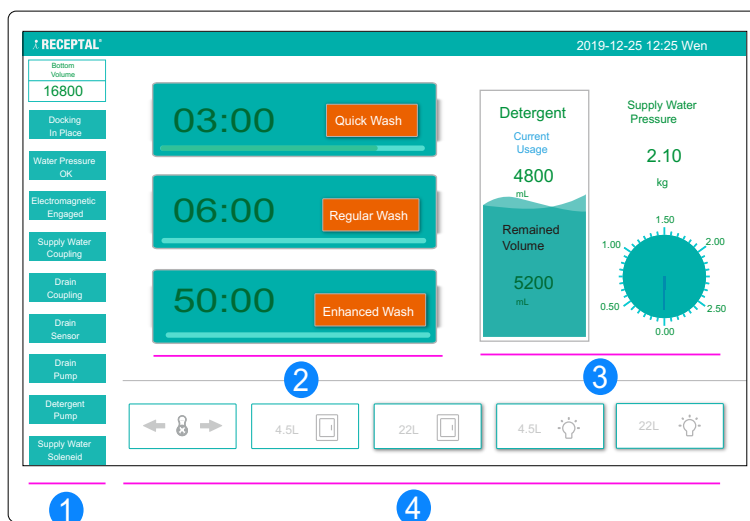

The Wash Cycle View is divided into four functional sections:

1. The left section presents the internal connections of the system.
2. The middle section is the three Wash Cycle BUTTONs, for the wash cycle options, please refer to the “Wash Cycle Options Table”.
3. The right section shows the shows a graphical presentation of the detergent volume and the pressure of the fresh water.
4. The bottom section, from the left to the right is the manifold socket, Upper and Lower Chamber windows, and the Upper and Lower Chamber lights soft BUTTONs. For the definitions of these soft BUTTONs, please refer to the Main View section.

Popup View

The popup view indicates an action you need to take to continue the procedure. Depending on the situation, the popup view can contain multiple options as soft BUTTONs or only one option for acknowledging the situation (for example, Confirm). The popup view disappears when you select one of the soft BUTTON options.

The device provides visual and audible alarm signals when an error condition is present. For the

error conditions and informative messages and the actions to be taken, see the "Error" section.

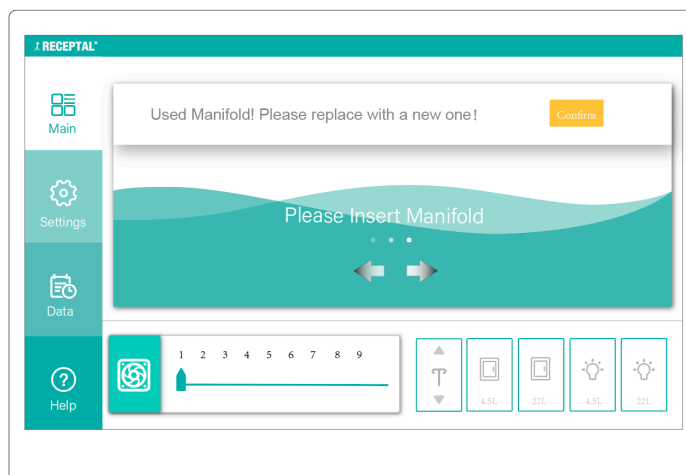

Popup Notification Message

Popup Notification	Description	Action
Used Manifold! Please replace with a new one.	Manifold has been used.	Replace manifold.
Please close the Manifold socket.	Manifold has been taken out.	Tap the left arrow icon to close the Manifold socket.
No Smoke Filter is detected. please install a smoke filter.	No Smoke Filter detected.	Replace smoke filter.
The smoke filter will expire in XX minutes. It can work about another XX minutes. please replace the filter timely.	Smoke filter will expire shortly.	Replace smoke filter.
Smoke filter expired. Please replace with a new one.	Smoke filter expired.	Replace smoke filter.
Please attempt to dock again.	Docker communication error	Dock rover again.
Insufficient supply water pressure! please adjust the supply water pressure setting or add water booter pump as necessary to assure desired cleanness.	Supply water which connected to docker is below the standard pressure.	Adjust the supply water pressure setting or add water booter pump as necessary.
Detergent volume low! please add detergent.	Detergent volume low.	Add detergent into detergent canister.

Definitions

Suction Setting Colors

COLOR	SUCTION LIMIT	RANGE
Orange -	Maximum	528mmHg/70kPa

	High	481 to 528mmHg/ 61 to 70kPa
Yellow- Orange	Medium	76 to 480mmHg/ 10 to 60 kPa
Green-	Low	37 to 75mmHg/ 5 to 10 kPa
Grey-	Off	0 ~ 37mmHg/ 0 ~ 5 kPa

Notification Message

Notification Message	Action
Canister full, Dock the Rover	Relocate the rover to the docker and dock the rover
High vacuum in operation	Do not need any action





Audible Event Indicators



















This table describes the indications associated with each type of system event.







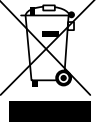







TYPE	INDICATION
Manifold	Manifold identified, ready to use
High vacuum	High vacuum in operation
Canister full	Canister full, please dock the Rover
Error	Error
Lower chamber full	Lower chamber full
Dock	Docking in place
Smoke evacuator filter	Smoke evacuator filter about to its useful life

Symbols

The following symbols appear on the device and/or its labeling. For more information, see “Technical specifications”

Symbol	Description
Symbols on device	
	ON (POWER)
	OFF (POWER)
4.5L	4.5-LITER (4.5L) Chamber of the canister
22L	22-LITER (22L) Chamber of the canister
	ALTERNATING CURRENT (AC)
	DIRECT CURRENT (DC)

	Type CF applied part, protection class against electrical shock
	General warning sign
	Refer to instruction manual/booklet
	This symbol is located near the protective ground locations on this device
	Caution: non-ionizing electromagnetic radiation
	Footswitch
	HIGH VACUUM/HIGH FLOW Continuous Surgical Suction Range: -5 to -70 kPa / -37 to -528 mmHg
	Manifold socket
	SMOKE FILTER COMPARTMENT
	AUXILIARY SUCTION PORTS
	Do not connect directly to chest tubes
	Do not connect directly to tracheal tubes
	Do not connect to closed wound drains
	This symbol signifies that the device is in conformity to the specifications of the Council Directive 93/42/EEC for medical products.
	Manufacturer. Date of manufacture.
	Catalog number
	Serial number
	Marking of electric and electronic equipment in accordance with Directive 2002/96/EC indicating separate collection for WEEE-Waste of electrical and electronic equipment when disposed.
Symbols on consumables	
	Consult instructions for use
	Do not reuse

	Batch code
	Caution
	Latex free
	DEHP free
Symbols on exterior packaging	
	Fragile – handle with care
	This end up
	Keep dry
	Keep away from sunlight
Transport and storage conditions	
	Temperature limit: -20°C ~+40 °C
	Humidity limitation: 10% ~75%
	Atmospheric pressure limitation: 500 hPa ~ 1060 hPa
Operating conditions	
	Temperature limit: 10°C ~+40 °C
	Humidity limitation: 30% ~75%
	Atmospheric pressure limitation: 700 hPa ~ 1060 hPa

Symbols used in graphical user interface are explained in section System Overview.

Instructions

Before First Use

To Unpack the Rover

⚠ WARNING: HEAVY EQUIPMENT - ALWAYS have more than one person unpack and move this equipment from the shipping pallet. See the Specifications section for rover weight. Failure to comply may result in personal injury.

1. Remove the exterior packaging materials from the rover and recycle the material as required.

2. Using at least two people, remove the rover from the shipping pallet.
3. Inspect the rover and components for damage. If damage is apparent, DO NOT use the equipment.

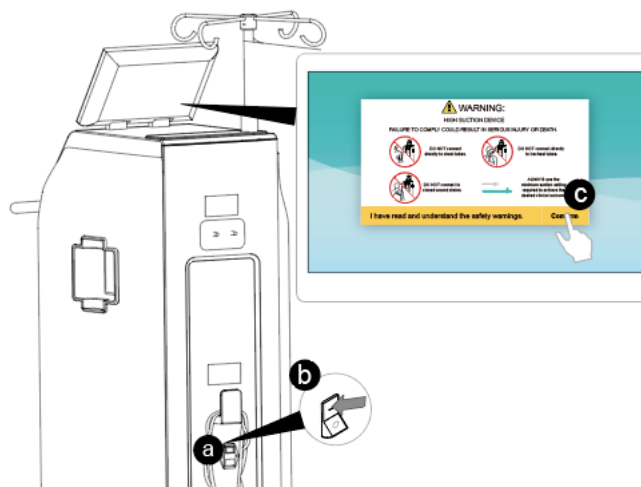

To Initially Dock the Rover

See the To Dock the Rover section to perform initial docking of the rover.

To Test the Rover

1. To Connect Power

- a. Connect the rover to facility electrical power using the power cord.
- b. Tap the power switch to the ON position.
- c. Read the WARNING message on the user interface, then tap the OK BUTTON to access the CONTROL screen (Figure 7).

Figure 7 To Connect Power

2. To Test Fluid Suction

- a. After control the user interface, following the instructions of Patient information input view to input the patient information directly or skip it by tapping the “skip” BUTTON below (Figure 8a). See the Patient information input view section for more information.
- b. Following the instructions of Manifold installation view to install a new disposable manifold into the manifold socket. Make sure the manifold is fully inserted and locked into place(Figure 8b, 8c). See the instructions for use supplied with the manifold for more information.
- c. Tap the START SUCTION BUTTON to start the vacuum pump (Figure 8d). Make sure the vacuum pump starts. If not, see the Troubleshooting Section.
- d. Tap the SUCTION SETTING BUTTON to input or use the “Suction Setting Bar” to adjust the SUCTION level to the maximum suction level. Make sure the value displayed on the user interface changes and reaches a maximum suction level between 520 and 528 mmHg/ 68-70kPa. If not, see the Troubleshooting section.

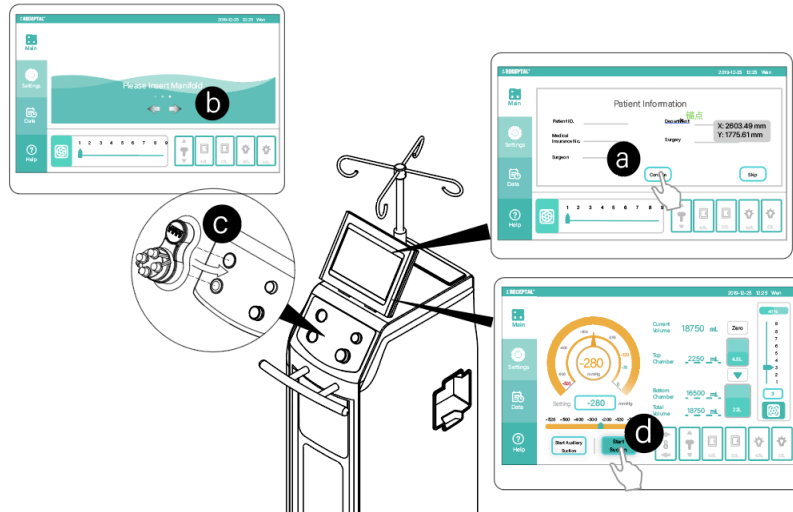

Figure 8 To Test Fluid Suction

3. To Test Smoke Evacuation

NOTE: Make sure a smoke evacuator filter is installed in the rover before testing smoke evacuation. See the Accessories section. See the instructions for use supplied with the smoke evacuator filter for installation information.

- a. Optional: Attach Footswitch plug into appropriate jack on front of Rover.
- b. Tap the "Smoke Evacuator" BUTTON (Figure 9) or Depressing and Releasing the footswitch (if connected).
- c. Adjust the evacuation level to the desired setting by sliding the "Smoke Evacuator Power Setting" bar or tapping the "Smoke Evacuator Power Setting" BUTTON to input (Figure10). Make sure the smoke evacuation functions correctly. If not, see the Troubleshooting section.

NOTE: See the "To Adjust the Rover Settings" section to make setting changes as required.

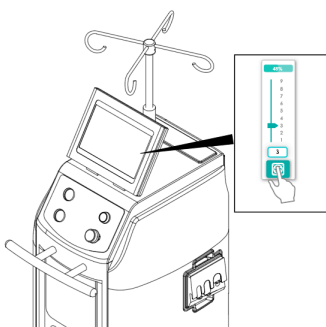

Figure 9 To Test Smoke Evacuation

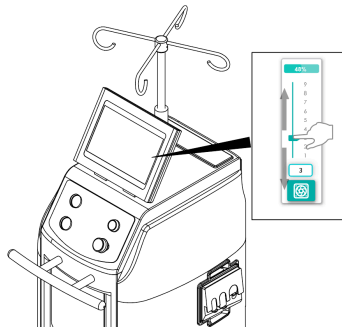

Figure 10 To Adjust Smoke Evacuation

4. To Test the IV Pole

Tap the UP and DOWN ARROW of the IV Pole to control the IV pole (Figure 11). Make sure the IV pole functions correctly. If not, see the Troubleshooting section.

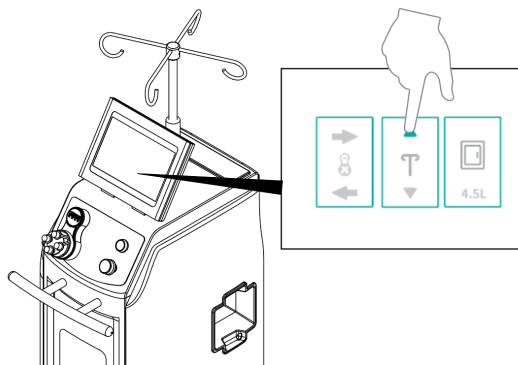

Figure 11 To Test IV Pole

5. To Test the Chamber access doors

Tap the Upper and Lower Chamber access door BUTTONS that control the Chamber access doors (Figure 12). Make sure the Upper and Lower Chamber access door functions correctly. If not, see the Troubleshooting section.

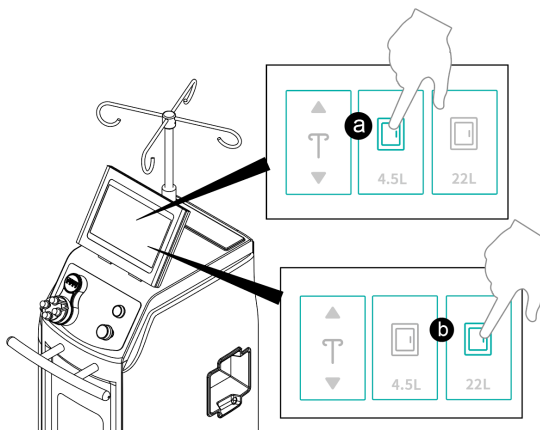
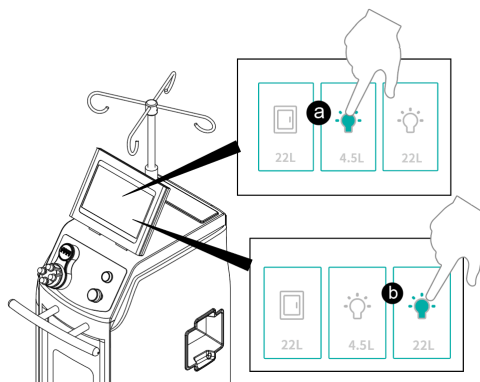

Figure 12 To Test Upper and Lower Chamber access door

6. To Test the Chamber lights

Tap the Upper and Lower Chamber light BUTTONS that control the Upper and Lower Chamber lights (Figure 13).



13). Make sure the Chamber light functions correctly. If not, see the Troubleshooting section.

Figure 13 To Test 4.5-liter Chamber light

To Adjust the Rover Settings

1. Make sure the power cord is connected between the rover and facility power.

2. Make sure the power switch is in the ON position and the HIGH SUCTION DEVICE WARNING has been acknowledged. Make sure the manifold is installed correctly.
3. From the user interface, tap the Settings BUTTON to open the system setup view (Figure14).
4. From the system settings view, tap as needed to select the system settings you want to adjust (Figure15).
5. After setting adjustments are completed, the custom settings will be saved. For more setup information, please refer to the “Settings View” section and the “System Setting Options” section.

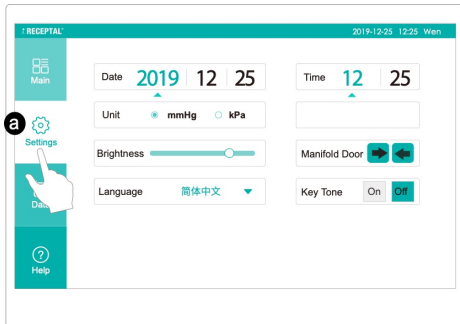

Figure 14 open the system setup view

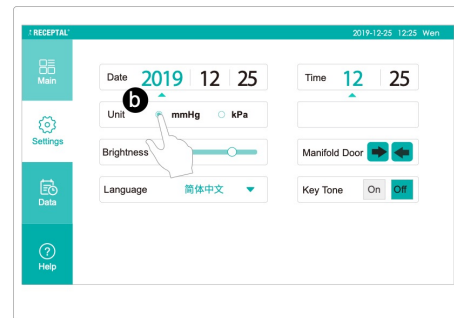

Figure 15 To Adjust the Rover

NOTE: After adjusting the rover system settings, disconnect the rover from facility power and wrap the power cord around the power cord bracket. The rover is now ready to be used in an operating room setting.

Before the Procedure

To Setup the Rover

⚠ WARNINGS:

- Upon initial receipt and before each use, inspect each component for damage. DO NOT use any equipment if damage is apparent or the inspection criteria are not met. See the Inspection and Maintenance section for inspection criteria. DO NOT use the rover until it has been tested properly to ensure functionality. See the To Test the Rover section.
- ALWAYS clean the equipment as indicated upon initial receipt and before each use. DO NOT place the rover within the sterile field. Failure to comply may cause infection and result in patient or healthcare staff injury.

CAUTION: DO NOT clamp or attach any accessory onto the pole or base of the powered IV pole assembly.

NOTES:

- DO NOT use the rover until the docker has been installed and tested properly to ensure functionality. See the instructions for use supplied with the docker.
- ALWAYS close unused manifold ports and remove or clamp unused tubing to maintain optimal suction levels.

1. To Connect Power

- a. Position the rover on a flat surface and in a convenient location within the operating room.
- b. Lock the rover's two front casters to prevent rover movement (Figure 16b).

- c. Orient the rover's touch screen for optimal viewing (Figure 16c).

CAUTION: ALWAYS use the correct power cord. Configurations may vary. See the Accessories section for power cord options.

- d. Connect the rover to facility electrical power using the appropriate power cord (Figure 16d).
- e. Push the power switch to the ON position (Figure 16e).
- f. Read the WARNING message on the user interface, then tap the "Confirm" BUTTON to access the CONTROL screen (Figure 16f).
- g. From the main view, tap the chamber access door BUTTONs to Open the canister access doors to allow viewing of the contents (Figure 16g).

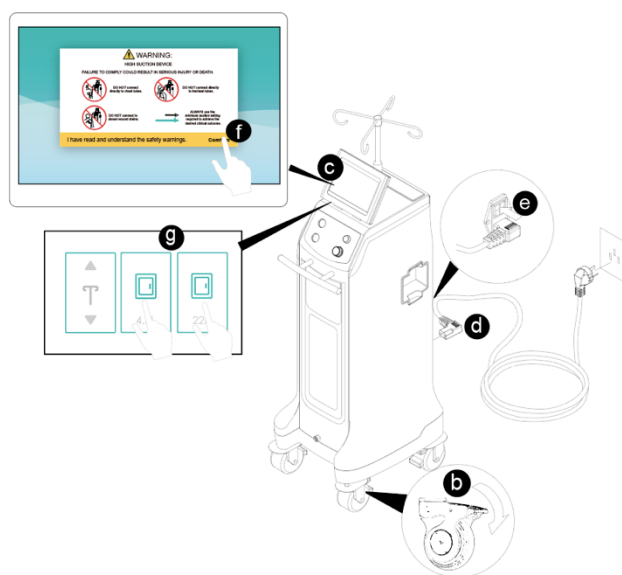

Figure 16 To Connect Power

2. To Prepare For Fluid Suction

NOTE: The fluid suction tubing and suction accessory are applied parts.

- a. After control the user interface, following the instructions of Patient information input view to input the patient information or skip it by tapping the "skip" BUTTON below. See the Patient information input view section for more information (Figure 17a).
- b. Following the instructions of Manifold installation view to install a new disposable manifold into the manifold socket. Make sure the manifold is fully inserted and locked into place. See the instructions for use supplied with the manifold for more information (Figure 17b).
- c. Attach the fluid suction tubing to the port(s) of the installed manifold. ALWAYS close unused manifold ports (Figure 17c).
- d. Attach a fluid suction accessory to the end of the suction tubing if required (Figure 17d).

- e. To reset the current volume display if required (Figure 17e).

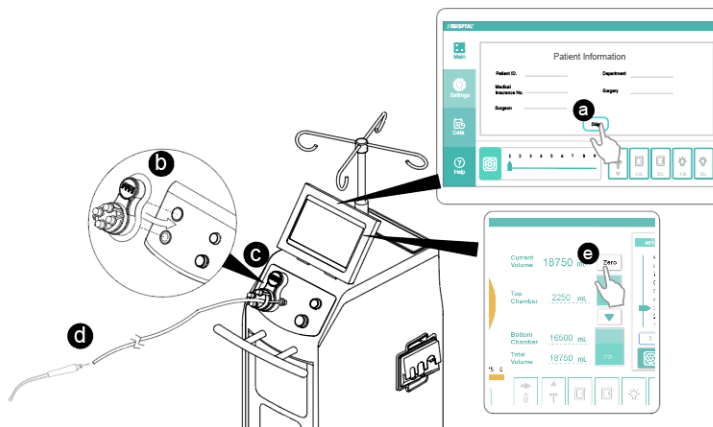

Figure 17 To Prepare for Fluid Suction

3. To Prepare For Smoke Evacuation

NOTES: Make sure a smoke evacuator filter is installed in the rover before using smoke evacuation. See the Accessories section. See the instructions for use supplied with the smoke evacuator filter for installation information.

- a. Install the smoke evacuator tubing to the smoke evacuator filter (Figure 18a).
- b. Attach a smoke evacuator accessory to the end of the smoke tubing, if required (Figure 18b).
- c. Optional: Attach Footswitch plug into Footswitch jack on front bottom of Rover (Figure 18c).

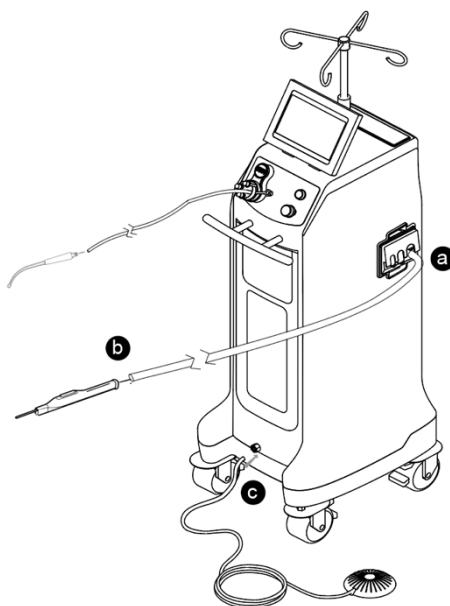

Figure 18 To Prepare for Smoke Evacuation

4. To Use the IV Pole

- a. Hang one irrigation bag on each IV pole hook, if required. The maximum volume allowed per hook is 3000 milliliters (Figure 19a).
- b. Tap and hold the IV pole UP arrow BUTTON to raise the IV pole to the desired height (Figure 19b).

c. See the To Operate the Rover section.

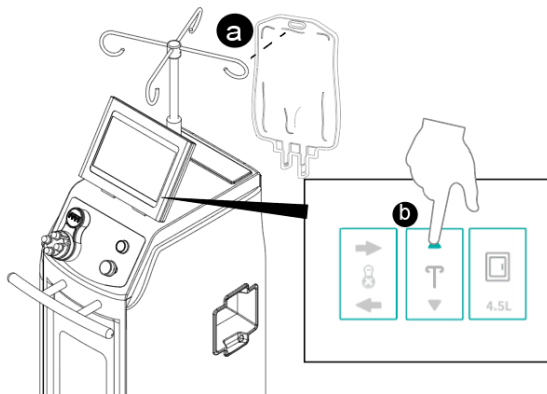

Figure 19 To Use the IV Pole

5. To Use the Chamber lights

a. Tap the Upper/Lower Chamber light BUTTON to turn on the Chamber lights to illuminating the upper/Lower chamber (Figure 20).

b. See the To Operate the Rover section.

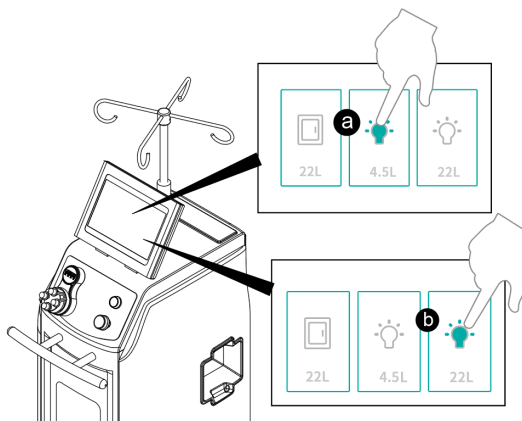

Figure 20 To Use Chamber lights

During the Procedure

To Operate the Rover

⚠ WARNINGS:

- HIGH SUCTION DEVICE [MAX = -528 mmHg/ -70kPa]
 - The effectiveness of aspiration is dependent upon the intensity of the vacuum applied.
 - ALWAYS use the minimum suction setting required to achieve the desired clinical outcome.
 - ALWAYS follow your institution's guidelines for suction limits.
 - DO NOT connect directly to chest tubes.
 - DO NOT connect to closed wound drains.
 - DO NOT connect directly to tracheal tubes.
 - NOT FOR USE as a suction source for intermittent suction applications.

Death or serious injury can result from improper suction levels.

- The canister scale and fluid volume display are not diagnostic tools. DO NOT use the scale or fluid volume display to determine the amount of fluid lost from or retained by the patient.
- ALWAYS make sure rover power is ON when collecting fluid waste. The rover can only detect full canister if the rover is ON. If the rover is OFF, biohazard waste leakage or loss of suction can occur.
- The suction setting may only be adjusted by the SUCTION SETTING on the user interface. Interruption and restoration of rover power, whether accidental or intentional, does not reset the suction setting to zero.
- LOW SUCTION HAZARD

NOT FOR USE as a suction source for the following applications:

- Organ stabilizer/positioner devices
- Patient positioner devices

Death or serious injury can result from fluctuating suction levels.

NOTES:

- This equipment provides an adjustable suction limit of 37 to 528 mmHg/5 to 70kPa measured with all ports closed.
- Make sure the rover has been prepared for collection properly. See the To Setup the Rover section.

1. To Control Fluid Suction

NOTE: See the High Suction Indicator table for important condition, indication and action information.

- While viewing the CONTROL screen on the user interface display, tap the SUCTION SETTING BUTTON or slide the Suction level gauge to adjust to the desired suction level (Figure 21).
- Tap the START SUCTION BUTTON to start fluid suction (Figure 22).

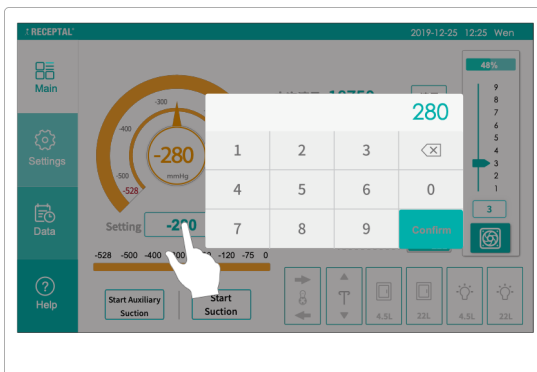

Figure 21 To Set Suction Level

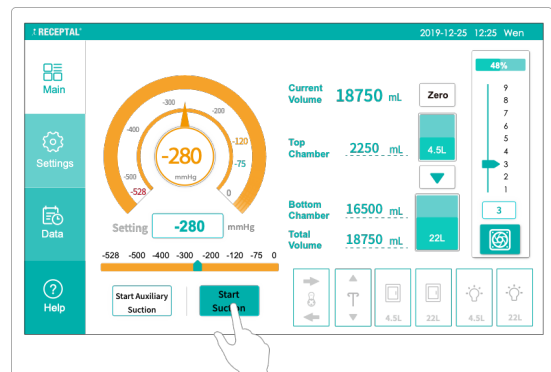

Figure 22 To Start Fluid Suction

High Suction Indicator

NOTE: The condition, indication and action described in this table pertain to one or both canisters

SUCTION CONDITION	INDICATION	ACTION
HIGH SUCTION LIMIT RANGE: the	one "High vacuum in operation" voice	Confirm whether a high range is

suction setting selected is at or above 450 mm-Hg/60kPa	with user interface display flashes "High vacuum in operation"	desired.
---	--	----------

2. To Control Smoke Evacuation

- a. Tap the BUTTON that appears like a fan on the Touch screen (Figure 23) or depressing and releasing the footswitch (if connected) to start or stop smoke evacuation.
- b. Tap the "Smoke Evacuator Power Setting" BUTTON to input or use the "Smoke Evacuator Power Setting"

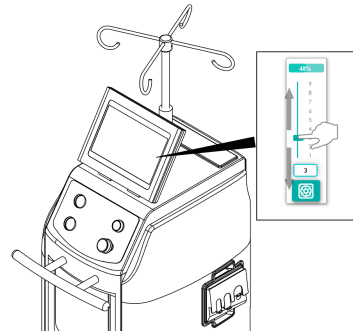
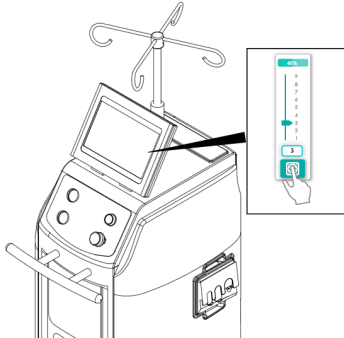

bar that located on the top of the fan image to adjust the amount of smoke suction, the motor speed is increased or decreased by 10% as the speed is from 1 (20% of the maximum speed) to 9 (100% of the maximum speed)) (Figure 24). The smoke suction control should be set at the lowest practical setting to completely remove the surgical smoke from the operative site.

Figure 23 To Control Smoke Evacuation

Figure 24 To Adjust Smoke Evacuation

3. To Adjust the IV Pole

Tap and hold the IV pole UP or DOWN arrow BUTTONs to raise or lower the pole height, respectively (Figure 25).

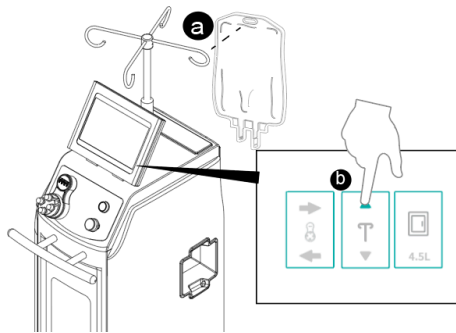

Figure 25 To Adjust IV Pole

4. To Open or Close the Chamber access doors

Tap the Upper or Lower Chamber access door **BUTTONS** to open/close the Upper and Lower Chamber access door (Figure 26).

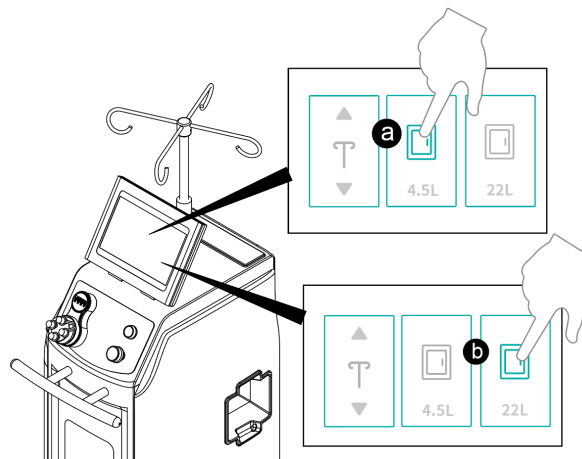
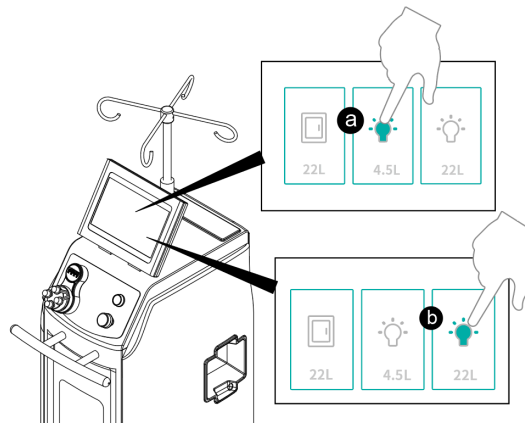

Figure 26 To open or close Upper and Lower Chamber access door

5. **To Turn On or Turn Off the Chamber lights**

Tap the Upper or Lower Chamber light **BUTTONS** to turn on/turn off the Upper and Lower Chamber light (Figure



27).

Figure 27 To turn on or turn off the Chamber lights

6. **To Manage Full Canister**

NOTE: See the Fluid Volume Indicators table for conditions, indications and actions related to a full or almost full canister.

- a. If the 4.5-liter chamber is full, the contents in the 4.5-liter chamber would flow into the 22-liter chamber automatically. Tap the **EMPTY 4.5L CANISTER BUTTON** on the user interface anytime if you want to empty the 4.5-liter chamber (Figure 28).
- b. If the 22-liter chamber is full, shutdown the rover for relocation. Dock the rover to empty the full canister. See the **To Dock the Rover** section.

NOTE: If the 22-liter chamber has insufficient capacity to receive the 4.5-liter chamber fluid, a screen will appear indicating the rover will require shutdown and docking to empty its full canister.

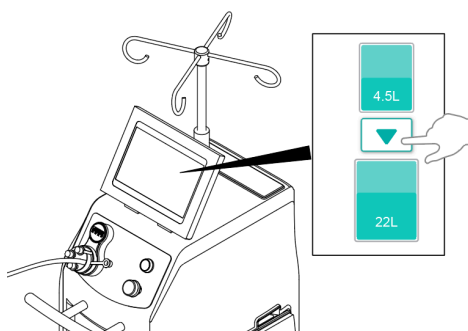

Figure 28 empty 4.5l chamber

NOTES:

The EMPTY 4.5L CHAMBER action will continue until the 22-liter chamber can no longer receive fluid waste or the 4.5-liter chamber is empty.

A maximum of four EMPTY 4.5L CHAMBER cycles are allowed between docking cycles.

The canister will return to their previous suction setting after the EMPTY 4.5L CANISTER action is complete.

Fluid Volume Indicators

FLUID VOLUME CONDITION	INDICATION	ACTION
Lower Chamber is full – The fluid volume level is near full capacity. Fluid suction will soon stop in the full canister.	One “Lower chamber full” voice; the Lower Chamber area flashes “Lower Chamber full”	Prepare to relocate and dock the rover to dispose of waste.
Canister full – The fluid volume level is at full capacity. Fluid suction has stopped in the full canister.	One “Canister full, please dock the Rover” voice; Touch screen flashes “Canister full, please dock the Rover”	Relocate and dock the rover to dispose of waste.

After the Procedure

To Shutdown the Rover

⚠ WARNING:

- **BLOODBORNE PATHOGEN HAZARD:**
 - ALWAYS wear personal protective equipment (PPE) when operating or handling this equipment.
 - ALWAYS leave tubing attached to the manifold and close unused ports during disposal.
 - ALWAYS follow local regulations regarding proper handling and disposal of biohazard waste.

Failure to comply may cause infection and result in healthcare staff injury.

1. To Remove Fluid Suction Components

- a. With suction active, gather the suction tubing toward the manifold port to purge the tubing of fluid waste. DO NOT remove any attached suction tubing from the manifold (Figure 29).
- b. Adjust the SUCTION level to zero.
- c. Push the “Suction Off/Stop Docking” button on the front panel to stop fluid suction (Figure 30).

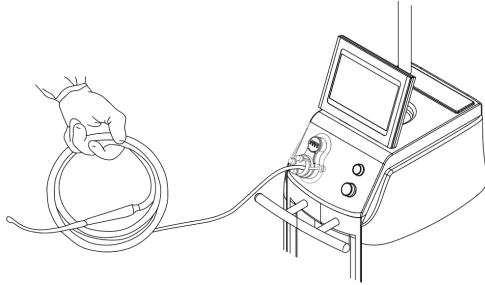

Figure 29 To Gather Suction Tubing

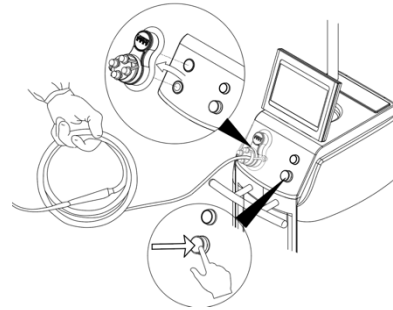

Figure 30 To Shutdown Suction

- d. Pull the manifold and attached suction tubing out of the receptacle, always keeping the manifold in a horizontal orientation (Figure 31).

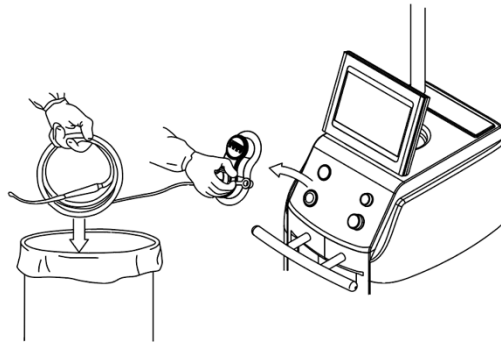

Figure 31 To Remove Manifold and Tubing

- e. Properly dispose of the used manifold and attached suction tubing always maintaining the manifold in a horizontal orientation.
- f. Remove all the remaining fluid suction accessories as required.
- g. Close the Manifold door by tapping the Manifold door left icon on the user interface

2. To Remove Smoke Evacuation Components

- a. Tap the BUTTON that appears like a fan on the Touch screen or depressing and releasing the footswitch (if connected) to stop smoke evacuation (Figure 32a).
- b. Remove the smoke evacuator tubing with any attachments (Figure 32b).

- c. Replace the Smoke filter when the filter life shows 3% life Remaining. Failure to change the filter will affect the performance of the smoke evacuation.

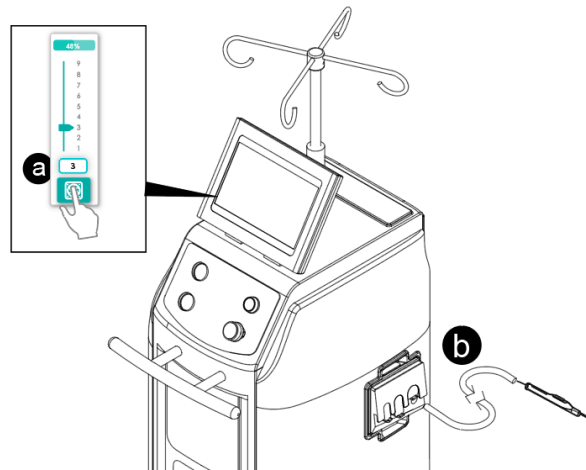

Figure 32 To Remove Smoke Evacuation Components.

3. To Remove IV Pole Components

- a. Tap the IV POLE DOWN BUTTON to lower the IV pole (Figure 33a).
- b. Remove any irrigation bags on the IV pole as required (Figure 33b).

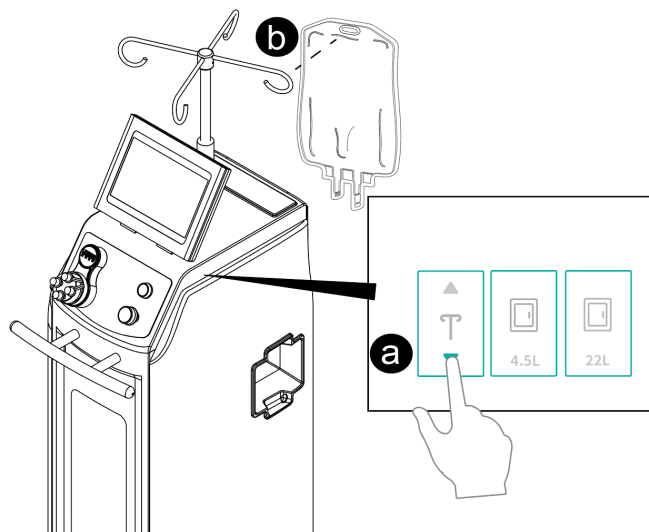

Figure 33 To Remove IV Pole Components

4. To Remove Power

- a. Turn off the chamber lights by tapping the light BUTTON on the user interface, if required.
- b. Close the chamber access doors by tapping the chamber access door BUTTONS on the user interface, if required.
- c. Push the power switch to the OFF position (Figure 34).
- d. Disconnect the rover from facility electrical power. Wrap the power cord around the cord bracket.

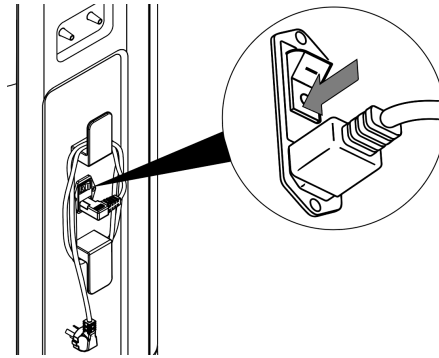

Figure 34 To Remove Power

5. To Prepare for Relocation

NOTE: Before relocation, remove all irrigation bags from the rover. The rover transport configuration is illustrated in Figure 35.

- a. ALWAYS wipe down the rover between each surgical use. See the Cleaning section.
- b. Unlock the four casters of the rover and relocate the rover as required.

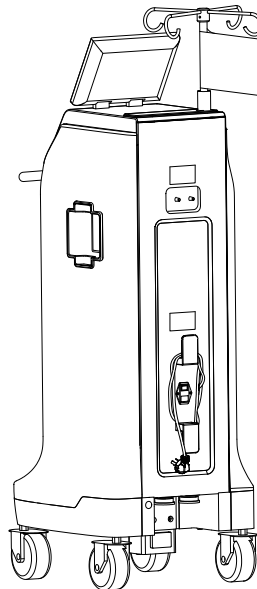

Figure 35 Transport Configuration

6. To Relocate the Rover

- a. If both chambers are full or the rover contains fluid waste and will not be used within two hours, relocate the rover to the dock. See the To Dock the Rover section.
- b. If the chambers are not full and the rover will be used within two hours, relocate the rover to the desired location. See the To Setup the Rover section.

NOTES:

- Dock the Rover for waste disposal as soon as practical, typically within two hours of the last use, to preclude extended wash cycles.
- The rover does not have to be connected to facility power when not in use.

To Dock the Rover

⚠ WARNINGS:

- ALWAYS keep hands out and away from the mating surfaces of the rover and docker during the docking procedure to avoid a pinch point hazard.
- BLOODBORNE PATHOGEN HAZARD
 - ALWAYS wear personal protective equipment (PPE) when operating or handling this equipment.
 - ALWAYS follow local regulations regarding proper handling and disposal of biohazard waste.
- Failure to comply may cause infection and result in healthcare staff injury.

NOTES:

- Dock the rover for waste disposal as soon as practical, typically within two hours of the last use, to preclude extended wash cycles.
- Before docking the rover, always allow the docker to warm up for at least 60 seconds after applying power to the docker.
- The docker provides power to the rover during the docking process.
- After docking the rover, DO NOT lock the rover casters.

1. To Prepare the Docker

- a. Make sure the power switch is in the ON position and illuminated.
- b. Make sure the bottle of Detergent has enough detergent to perform a wash cycle.

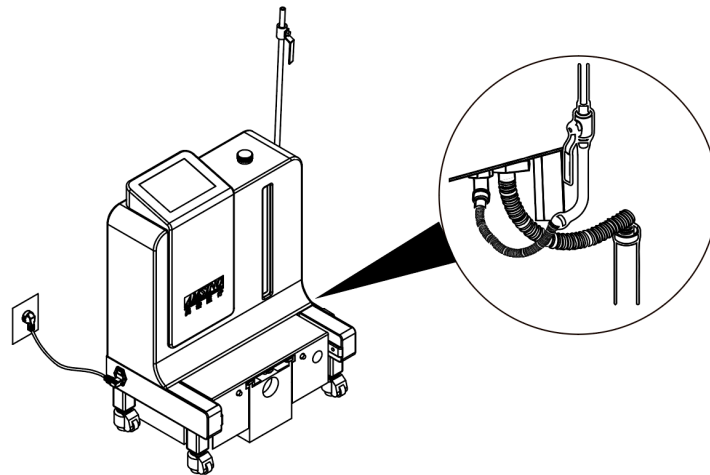

Figure 36 To Prepare the Docker

2. To Perform a Wash Cycle

- a. Push the rover toward the docker and between the guides until the rover and docker attach automatically (Figure 37).

- b. As the rover and docker attached together, the Wash Cycle View will display automatically and “Docking in place” voice message will be heard. From the Wash Cycle View select a cycle by tapping the related BUTTON. For the wash cycle options, refer to the wash cycle options table.

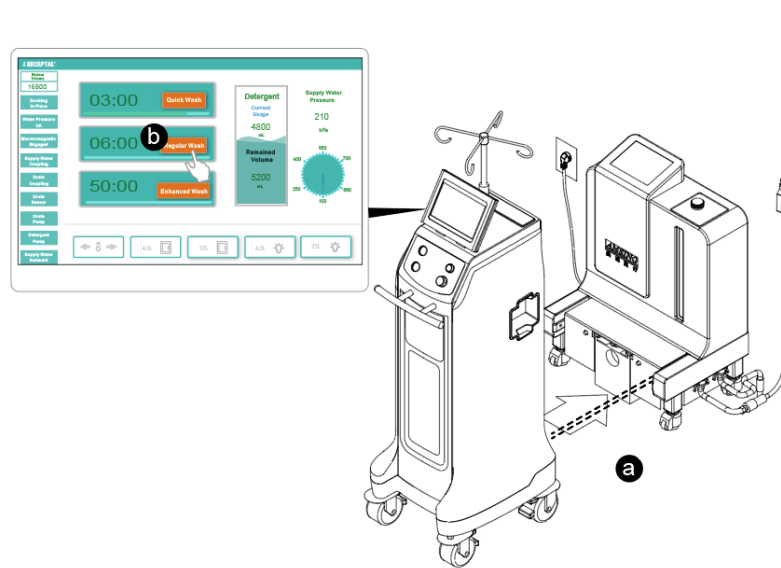

Figure 37 To Perform a Wash Cycle

NOTES:

- During the first rover docking procedure, the information on the user interface display may appear inconsistent. The procedure may also take a few more minutes than specified in the Wash Cycle Options table. Both conditions are normal and temporary.
- If a specific wash cycle is not selected within ten seconds, the “Wash” cycle will be performed automatically. See the Wash Cycle Options table.
- To exit the current wash cycle, push the “Stop Suction/Stop Docking” button to terminate the current a wash cycle and the rover detaches from the docker automatically (Figure 38). Pull the rover away from the docker. And dock again, select the needed wash cycle.

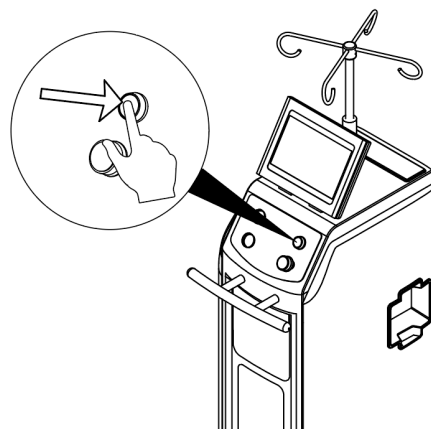

Figure 38 To cease the current wash Cycle

Wash Cycle Options

CYCLES	DESCRIPTION	TIME (approx.)
Wash	Cycle drains the contents, applies detergent to	6 minutes

	the interior walls of both chambers, and rinses the detergent with water.	
Quick Drain	Cycle drains the contents of both chambers.	3 minutes
Extended Wash	Cycle drains the contents, applies detergent to the interior walls of both chambers and rinses the detergent with water. Intermittent periods of soaking occur during the cycle.	50 minutes

- c. After the cycle is complete, the rover detaches from the docker automatically. Pull the rover away from the docker.
- d. Visually inspect the chambers for any remaining soil. If soil remains, an Extended Wash cycle is available to provide a more thorough cleaning of the chambers.

NOTE: If this is the initial docking of the rover, make sure the rover is tested before use. See the To Test the Rover section.

Inspection and Cleaning Maintenance

WARNINGS:

- Upon initial receipt and before each use, inspect each component for damage. DO NOT use any equipment if damage is apparent or the inspection criteria are not met.
- DO NOT disassemble, modify, service, or repair any system component or accessory, unless otherwise specified. Call AMSINO iReceptal Customer Service.

NOTES:

- Only individuals trained and experienced in the maintenance of reusable medical devices should install, inspect, and test this equipment.
- For service, contact your AMSINO sales representative or call AMSINO iReceptal Customer Service. Outside the US, contact your nearest AMSINO subsidiary.
- Maintenance documentation for this equipment is available upon request to AMSINO-authorized service personnel only.

INTERVAL	INSPECTION CRITERIA	ACTION
Before initial use	Check equipment for damage or missing components and for proper operation.	If damage is apparent, replace the equipment. See the Accessories section.
	Make sure the rover and docker operate as a system properly.	See the following sections: To Dock the Rover, To Test the Rover, and To Adjust the Rover Settings.
Before each use and after each cleaning	Check equipment for damage or missing components.	If damage is apparent, replace the equipment. See the Accessories section.
	Check for cleaning induced damage or unacceptable deterioration on all external surfaces of the rover, such as	

	corrosion, discoloration, pitting, or cracked materials.	
	Check the canister and smoke evacuator filter cover, for cracks or damage.	
	Check the four casters with locks and make sure the locks function properly.	
	Check the power cord for cuts and the power cord plug for bent pins.	
	Check the power cord receptacle for bent pins or bent contacts.	
Six months	Check the replacement date on the smoke evacuator filter label. The smoke evacuator filter life is 80 hours.	Replace the smoke evacuator filter every six months or as indicated on the user interface display. See the Accessories section.

NOTE: If any component must be discarded, see the Disposal/Recycle section.

Cleaning Maintenance

⚠ WARNING: ALWAYS clean the equipment as indicated upon initial receipt and before each use. Failure to comply may cause infection and result in patient or healthcare staff injury.

CAUTIONS:

- DO NOT immerse any system component in liquid. DO NOT allow liquids or moisture to enter any electrical connection.
- DO NOT sterilize any system component.
- DO NOT use solvents, lubricants, or other chemicals, including glutaraldehyde or similar chemical cleaners, unless otherwise specified.
- Use of unapproved disinfectants may cause system damage.

Recommended Equipment

- Personal Protective Equipment (PPE) as recommended by the disinfectant supplier (minimum: gown, gloves, face/eye shield)
- Soft, lint-free cloth
- Environmental Protection Agency (EPA) registered disinfectant with a claim for activity against Hepatitis B. The following disinfectants have been validated for use with the AMSINO iReceptal 3 Waste Management System:
 - Sodium Hypochlorite Based - Clorox Clean-Up Disinfectant Cleaner with Bleach (EPA Reg. #67619-1)
 - Quaternary Ammonium Based - CaviCide (EPA Reg. #46781-6)

To Wipe Down the Rover

1. Wipe the external surfaces of the rover with a soft, lint-free cloth moistened with a non-abrasive, hospital disinfectant prepared according to the manufacturer's instructions. Clean surfaces until all visible soil is removed.
2. Wipe critical areas such as the handle, user interface, manifold port, and any other areas that may have become soiled. Including the infrared communication window.

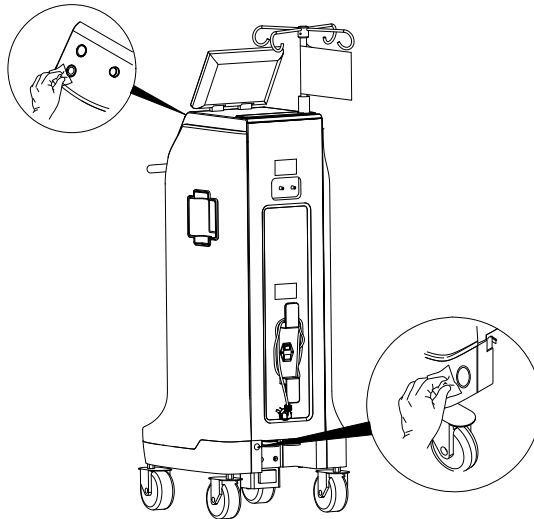

Figure 39 To wipe down the rover

3. Using a clean cloth moistened with disinfectant, wipe all surfaces. Make sure all surfaces remain visibly wet at room temperature for at least the minimum time specified in the instructions supplied by the disinfectant manufacturer.
4. Remove any excess disinfectant solution using a soft, lint-free cloth moistened with water if required by the instructions supplied by the disinfectant manufacturer.
5. Inspect the rover. See the Inspection and Maintenance section.
6. If the rover will be used again, use the rover handle to Tap and relocate the rover. See the To Setup the Rover section. If the rover will no longer be used, use the rover handle to Tap and relocate the rover to a storage area.

Storage and Handling

CAUTIONS:

- ALWAYS store and transport the equipment within the specified environmental condition values throughout its useful life. See the Specifications section.
- ALWAYS call AMSINO iReceptal 3 Customer Service before transporting or storing this equipment in freezing conditions. Failure to comply will cause the expansion of frozen internal fluid to damage the equipment.

To ensure the longevity, performance and safety of this equipment, use of the original packaging material is recommended when storing or transporting this equipment.

Disposal/Recycle

⚠ WARNINGS:

BLOODBORNE PATHOGEN AND CONTAMINATION HAZARDS

- ALWAYS follow local regulations for safe handling, recycling, and disposal of biohazardous fluid waste and iReceptal digital surgical suction equipment.
- Call AMSINO iReceptal 3 Customer Service for rover decontamination procedures.
- Discarded electromedical equipment must not be disposed together with waste but must be collected separately to guarantee ecologically correct disposal to prevent dispersion of potential pollutants into the environment. Please hand in the device at the end of its useful life to the local collection and recycling point for electrical and electronic devices.

Failure to comply may cause environmental contamination or infection and result in personal injury.



Per the European Community (EC) Waste Electrical and Electronic Equipment (WEEE) Directive 2012/19/EU, product must be collected separately. DO NOT dispose of as unsorted municipal waste. Contact local distributor for disposal information.

Troubleshooting

NOTE: For service, contact your AMSINO sales representative or call AMSINO iReceptal Customer Service.

PROBLEM	POTENTIAL CAUSE	CORRECTIVE ACTION
Rover Operation		
The rover does not power up and the power switch is in the ON position.	Power cord is not connected or is not connected securely.	Connect the power cord or make sure the power cord is connected securely.
No vacuum pump action after the SUCTION BUTTON is Taped.	Canister is full and an error occurs.	Dock the rover.
	Solid or liquid material has entered the vacuum pump.	Remove the rover from use. Contact AMSINO iReceptal Customer Service.
	An internal fuse is blown.	Remove the rover from use. Contact AMSINO iReceptal Customer Service.
The rover's fluid suction is weak or insufficient.	Manifold is not installed correctly.	Insert the manifold to make sure it is locked in place.
	Unused manifold ports are open.	Close all unused manifold ports of each canister.
	Suction tubing connection is not secure.	Make sure all suction tubing connections are secure.
	Unused suction tubing is not clamped.	Clamp any suction tubing not in use.
	Suction tubing is blocked or damaged.	Clear or replace the suction tubing.

	Suction accessory is blocked or damaged.	Clear or replace the suction accessory.
	Suction tubing is too long or has a narrow diameter.	Use shorter length or larger diameter suction tubing.
	Manifold is damaged.	Replace the manifold. See the Accessories section. See the instructions for use supplied with the manifold.
	The SUCTION SETTING are too low.	Adjust the SUCTION SETTING .
	The vacuum pump or internal sensor is damaged.	Remove the rover from use. Contact AMSINO iReceptal Customer Service.
The rover's suction capability is lost.	The vacuum pump is damaged.	Remove the rover from use. Contact AMSINO iReceptal Customer Service.
A filter error appears on the user interface display.	The smoke evacuator filter has exceeded its useful life.	Replace the smoke evacuator filter. See the Accessories section. See the instructions for use supplied with the filter.
The rover is releasing a strong odor.	The smoke evacuator filter has exceeded its useful life.	Replace the smoke evacuator filter. See the Accessories section. See the instructions for use supplied with the filter.
The smoke evacuator fails to operate after activation (EVACUATE SMOKE BUTTON is Taped).	The smoke evacuator is damaged.	Remove the rover from use. Contact AMSINO iReceptal Customer Service.
A smoke evacuator error appears on the user interface display.	The smoke evacuator filter is not installed.	Install the smoke evacuator filter. See the instructions for use supplied with filter.
	The smoke evacuator filter is installed incorrectly.	Install the smoke evacuator filter again. See the instructions for use supplied with filter.
	The smoke evacuator is damaged.	Remove the rover from use. Contact AMSINO iReceptal Customer Service.
IV pole height cannot be adjusted to its maximum height.	IV pole is supporting too much weight.	Remove excessive weight from IV pole.
	The IV pole is bent, kinked, or pinched.	Remove the rover from use. Contact AMSINO iReceptal Customer Service.
Fluid does not drain from the 5-liter chamber into the 25-liter	A fluid waste clog exists at the bottom of the 4.5-liter chamber.	Remove the rover from use. Close all used and unused manifold

chamber after Taping the EMPTY 4.5L CHAMBER BUTTON.		ports. Turn both SUCTION SETTING dials to the maximum value. Tap the SUCTION BUTTON. Tap the EMPTY 4L CHAMBER BUTTON. Contact AMSINO iReceptal Customer Service if the clog persists.
An error occurs during EMPTY 4.5L CHAMBER procedure.	More than four EMPTY 4.5L CHAMBER procedures have been attempted.	Dock the rover.
	The contents of the 4.5-liter chamber cannot fit into the 25-liter chamber.	Dock the rover.
Sporadic electrical interference is experienced.	Electrical noise is present.	Turn off all the electrical equipment not in use in the room.
		Relocate the electrical equipment to maximize the distance between the equipment. Increase spatial distance.
		Plug equipment into different outlets.

PROBLEM	POTENTIAL CAUSE	CORRECTIVE ACTION
Docking Operation		
The rover will not dock or an error has occurred during docking.	The docker power cord is not connected or is loosely connected.	Make sure the docker power cord is connected securely.
	The docker power switch is in the OFF position.	Make sure the power switch is in the ON position and illuminated. If power switch is OFF, Tap the power switch to the ON position. Wait 60 seconds. Dock the rover.
	The docker power switch is in the ON position, but not illuminated.	Make sure facility power is provided to the wall receptacle. If facility power is OFF, apply facility power to the docker. Wait 60 seconds. Dock the rover.
	The docker is not receiving facility water.	Make sure the water inlet hose is connected correctly. Make sure the facility water supply valve is open. Dock the rover.
	The docker requires a power reset.	Remove power, then apply power to the docker. Wait 60 seconds. Dock the rover.
	If the problem persists, the docker may be damaged.	Contact AMSINO iReceptal Customer Service.

The docker does not dispense detergent during the cleaning cycle.	The bottle of detergent is empty.	Replace the bottle of the detergent. See the Accessories section.
	If the problem persists, the docker may be damaged.	Contact AMSINO iReceptal Customer Service.
An error occurs while the rover is docked and the rover cannot be removed from the docker.	The fluid connectors prevent the removal of the rover from the docker.	Remove power, apply power to the docker. Wait 10 seconds. Pull the rover away from the docker. Wait 60 seconds. Dock the rover.
	If the problem persists, the fluid connectors may be damaged.	Contact AMSINO iReceptal Customer Service.
The rover cannot be removed from docker.	The four casters are locked.	Make sure the four casters are unlocked. The casters do not need to be locked when the rover is docked. Pull the rover away from the docker.

Error Messages

NOTE: For service, contact your AMSINO sales representative or call AMSINO iReceptal Customer Service.

Error Message	ACTION
VACUUM PUMP ERROR	CALL SERVICE
SMOKE EVAC ERROR	CALL SERVICE
LEVEL SENSOR OF UPPER CHAMBER OR VALVE BETWEEN CHAMBER ERROR	CALL SERVICE
AIR PUMP, SOLENOID VALVE, ERROR	CALL SERVICE
WATER PUMP OR LEVEL SENSOR OF LOWER CHAMBER ERROR	CALL SERVICE
DETERGENT PUMP ERROR	CALL SERVICE
SMOKE FILTER EXPIRED	REPLACE SMOKE FILTER
NO SMOKE FILTER DETECTED	SMOKE FILTER NOT DETECTED - REPLACE SMOKE FILTER

Specifications

The Software (also incorporated into the device) has minimum requirements concerning IT security measures, including protection against unauthorised access, necessary to run the software as intended laid out in the instruction for use (IFU)

TABLE 1. Rover specifications

REF	iRR301	iRR302
Electrical Power Requirements:	100-120V~, 50/60 Hz, 8 A, single phase 24 V =, 3 A during docking procedure; rover receives power from docker REF iRD301	220-240V~, 50/60 Hz, 4.5 A, single phase 24 V =, 3 A during docking procedure; rover receives power from docker REF iRD301
Power inlet module	Power switch with 250V fuses on neutral and line connection	Power switch with 250V fuses on neutral and line connection
European Conformity:		CE
Product Safety Certification:	IEC 60601-1:2005, IEC 60601-1:2005/AMD1:2012 Medical electrical equipment – Part 1: General requirements for basic safety and essential performance IEC 60601-1-2:2014 Collateral Standard: Electromagnetic disturbances – Requirements and tests IEC 60601-1-6:2010, IEC 60601-1-6:2010/AMD1:2013 Collateral Standard: Usability EN ISO 10079-3:2014 Medical suction equipment – Part 3: Suction equipment powered from a vacuum or positive gas source	EN 60601-1:2006/A1:2013 Medical electrical equipment – Part 1: General requirements for basic safety and essential performance EN 60601-1-2:2015 Collateral Standard: Electromagnetic disturbances – Requirements and tests EN 60601-1-6:2010/A1:2015 Collateral Standard: Usability EN ISO 10079-3:2014 Medical suction equipment – Part 3: Suction equipment powered from a vacuum or positive gas source RoHs directive 2011/65/EU
Dimensions	Width: 49.7cm Height: 254cm (with IV pole up); 153.8cm (with IV pole down) Depth: 66.5cm	
Mode of Operation	Continuous	
Volume	26.5 -liter capacity (combination of 4.5-liter and 22-liter chambers)	
Mass	97.85kg —collection empty 127.85kg —collection full	
Ingress Protection (IP):	IPX0	
Equipment Type:	Type CF Applied Part	
Equipment Classification:	Class I Medical Electrical (ME) Equipment	
Pollution Degree	2	
Environmental Conditions:	Operation:	

	<p>Temperature Limitation: 10°C ~ 40 °C</p> <p>Humidity Limitation: 30% ~ 75%</p> <p>Atmospheric Pressure Limitation: 70kPa ~ 106kPa</p> <p>Storage and Transportation (before initial use):</p> <p>Temperature Limitation: -20°C ~ 40 °C</p> <p>Humidity Limitation: 10% ~ 75%</p> <p>Atmospheric Pressure Limitation: 50kPa ~ 106kPa</p> <p>Storage and Transportation (after initial use):</p> <p>Temperature Limitation: 10°C ~ 40 °C</p> <p>Humidity Limitation: 10% ~ 75%</p> <p>Atmospheric Pressure Limitation: 50kPa ~ 106kPa</p>
Installation location	< 3,000 m above sea level. Usage not allowed in oxygen-rich or explosion- hazard environment.
IV Pole Capacity:	12,000 mL or 3000 mL per IV pole hook; for example four three-liter (3000 mL) IV bags
Light Emitting Diode (LED) Classification (infrared communication windows):	<p>WARNING: INVISIBLE LED RADIATION</p> <p>DO NOT VIEW DIRECTLY WITH OPTICAL INSTRUMENTS CLASS 1M LED PRODUCT — Viewing the laser output with certain optical instruments (for example, eye loupes, magnifiers and microscopes) within a distance of 100 mm may pose an eye hazard.</p>
Ground Type:	Protective Earth (ground); when connected to facility power
Suction	
Suction Limit range	37 to 528 mmHg at 1 mmHg increments; measured with all ports closed 5-70 kPa at 1 kPa increments; measured with all ports closed
Suction Tube Connection	Inner diameter: >6.0mm
Suction performance category	High vacuum/high flow
Vacuum Measurement range	0-80kpa
Vacuum Measurement Accuracy:	± 5% of full scale
Display resolution	1kPa/1mmHg. Suction level gauge
Fluid collection	
Display range	<p>upper chamber 0 ...5,000mL</p> <p>lower chamber 0 ... 25,000mL</p> <p>total volume 0 ... 30,000mL</p>
Measurement accuracy	<p>4.5L, ±50ml</p> <p>22L, ±150ml</p> <p>NOTE: Volume measurements specified do not account for fluid evaporation or an inclined plane of operation that exceeds the specified range.</p>
Smoke evacuation	
Maximum Smoke Evacuator Flow	Standard Hose I.D. Flow Rates

Setting	22mm (7/8").	707LPM (25CFM)
	9.5mm (3/8").	130LPM (4.6CFM)
	6.4mm (1/4").	60LPM (2.1CFM)
	NOTE: The specified flow rates were obtained using smoke tubing with a 1.8m length. Actual flow rates may vary depending on the length and diameter of the smoke tubing used.	
Smoke evacuation tube connection	6.4mm, 9.5mm, 22mm	

TABLE 2. Consumables specifications

Single-patient manifold	
Shelf life	3 years from manufacturing
Storage Conditions	Keep dry, Keep away from sunlight
ULPA filter	
Shelf life	3 years from manufacturing
Storage Conditions	Keep dry, Keep away from sunlight

Electromagnetic Compatibility

Guidance and Manufacturer’s Declaration

Below cables information are provided for EMC reference.

Cable	Max. cable length, Shielded/unshielded		Number	Cable classification
	4.5m	Unshielded		
AC Power Line	4.5m	Unshielded	1 Set	AC Power

Important information regarding Electro Magnetic Compatibility (EMC)

This electrical medical equipment needs special precautions regarding EMC and put into service according to the EMC information provided in the user manual; The equipment conforms to this IEC 60601-1-2:2014 standard for both immunity and emissions. Nevertheless, special precautions need to be observed:

- The equipment with no ESSENTIAL PERFORMANCE is intended used in Professional healthcare facility environment
- **WARNING:** Use of this equipment adjacent to or stacked with other equipment should be avoided because it could result in improper operation. If such use is necessary, this equipment and the other equipment should be observed to verify that they are operating normally”.
- The use of accessories, transducers and cables other than those specified or provided by the manufacturer of this equipment could result in increased electromagnetic emissions or decreased electromagnetic immunity of this equipment and result in improper operation.
- **WARNING:** Portable RF communications equipment (including peripherals such as antenna cables and external antennas) should be used no closer than 30 cm (12 inches) to any part of this product, including cables specified by the manufacturer. Otherwise, degradation of the performance of this equipment could result.”
- **WARNING:** If the use location is near (e.g. less than 1.5 km from) AM, FM or TV broadcast antennas, before using this equipment, it should be observed to verify that it is operating normally to assure that the equipment remains safe with regard to electromagnetic disturbances throughout the expected service life.
- **STATEMENT:** For the purpose of its operation, the equipment has wireless communication function, operating frequency range 13.56Hz

EMI Compliance Table (Table 1)

Table 1 - Emission

Phenomenon	Compliance	Electromagnetic environment
RF emissions	CISPR 11 Group 1, Class A	Professional healthcare facility environment

Harmonic distortion	IEC 61000-3-2 Class A	Professional healthcare facility environment
Voltage fluctuations and flicker	IEC 61000-3-3 Compliance	Professional healthcare facility environment

NOTE The EMISSIONS characteristics of this equipment make it suitable for use in industrial areas and hospitals (CISPR 11 class A). If it is used in a residential environment (for which CISPR 11 class B is normally required) this equipment might not offer adequate protection to radio-frequency communication services. The user might need to take mitigation measures, such as relocating or re-orienting the equipment.

EMS Compliance Table (Table 2-4)

Table 2 - Enclosure Port

Phenomenon	Basic EMC standard	Immunity test levels
		Professional healthcare facility environment
Electrostatic Discharge	IEC 61000-4-2	±8 kV contact ±2kV, ±4kV, ±8kV, ±15kV air
Radiated RF EM field	IEC 61000-4-3	3V/m 80MHz-2.7GHz 80% AM at 1kHz
Proximity fields from RF wireless communications equipment	IEC 61000-4-3	Refer to table 3
Rated power frequency magnetic fields	IEC 61000-4-8	30A/m 50Hz or 60Hz

Table 3 – Proximity fields from RF wireless communications equipment

Test frequency (MHz)	Band (MHz)	Immunity test levels
		Professional healthcare facility environment
385	380-390	Pulse modulation 18Hz, 27V/m
450	430-470	FM, ±5kHz deviation, 1kHz sine, 28V/m
710	704-787	Pulse modulation 217Hz, 9V/m
745		
780		
810	800-960	Pulse modulation 18Hz, 28V/m
870		
930		
1720	1700-1990	Pulse modulation 217Hz, 28V/m
1845		
1970		
2450	2400-2570	Pulse modulation 217Hz, 28V/m

5240	5100-5800	Pulse modulation 217Hz, 9V/m
5500		
5785		

Table 4 – Input a.c. power Port

Phenomenon	Basic EMC standard	Immunity test levels
		Professional healthcare facility environment
Electrical fast transients/burst	IEC 61000-4-4	±2 kV 100kHz repetition frequency
Surges Line-to-line	IEC 61000-4-5	±0.5 kV, ±1 kV
Surges Line-to-ground	IEC 61000-4-5	±0.5 kV, ±1 kV, ±2 kV
Conducted disturbances induced by RF fields	IEC 61000-4-6	3V, 0.15MHz-80MHz 6V in ISM bands between 0.15MHz and 80MHz 80%AM at 1kHz
Voltage dips	IEC 61000-4-11	0% U_T ; 0.5 cycle At 0°, 45°, 90°, 135°, 180°, 225°, 270° and 315°
		0% U_T ; 1 cycle and 70% U_T ; 25/30 cycles Single phase: at 0°
Voltage interruptions	IEC 61000-4-11	0% U_T ; 250/300 cycles

Appendix

To Use Auxiliary Suction Ports (optional)

The auxiliary suction ports allow connection to a hospital wall suction regulator if an alternate suction source is required.

⚠ WARNINGS:

- The rover CAN regulate hospital wall suction. ALWAYS use a hospital wall suction regulator to first control suction level and use the rover to second control and monitor suction level when using the auxiliary suction ports. Failure to comply could result in serious injury or death.
- ALWAYS make sure rover power is ON when collecting fluid waste. The rover can only detect full chambers if the rover is ON. If the rover is OFF, biohazard waste leakage or loss of suction can occur.

NOTES:

- The rover is equipped with two auxiliary suction ports. Connecting both auxiliary ports of a canister to the hospital wall suction regulator will increase airflow and improve suction performance compared to connecting only one auxiliary port of a canister.
 - If the ports are used, electrical power must be applied to the rover. The rover will regulate the vacuum level and will display vacuum and volume values and provide an audible indication if the canister fluid level exceeds its pre-defined limit.
 - Applying maximum suction up to 760 mmHg will not damage the rover.
1. Verify the rover is connected to facility power and Push the power switch to the ON position (Figure 40).

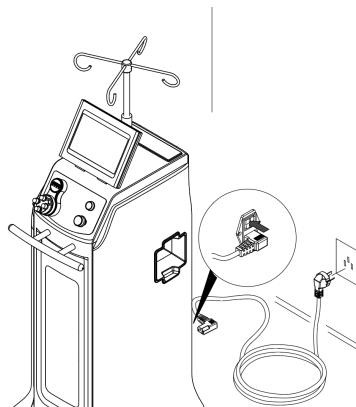

Figure 40 To Connect Power

2. Read the WARNING message on the user interface display, then Tap OK BUTTON to access the CONTROL screen.
3. Install a new disposable manifold into the manifold socket. Make sure the manifold is fully inserted and locked into place.
4. Attach suction tubing between the hospital wall suction regulator and the auxiliary suction ports on the rover (Figure 40).

5. Apply and regulate the suction level provided to the rover from the hospital wall suction regulator.
6. Tap the "Auxiliary Suction Port" on the touch screen to have the rover to second control the suction level (Figure 41).
7. Regulate and monitor suction level.
8. Pressing the Stop Suction button below the touch screen to stop Auxiliary Suction.

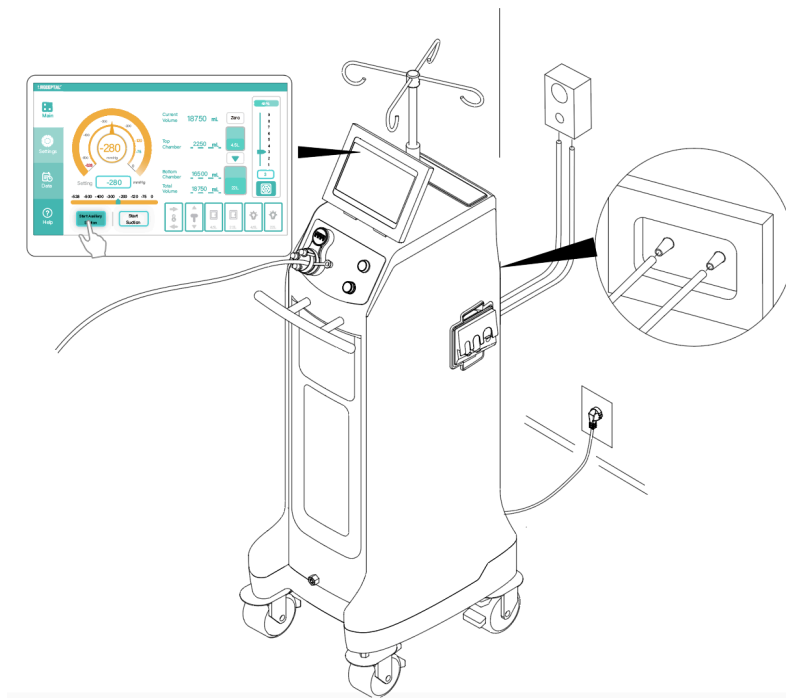

Figure 41 To Connect Auxiliary Suction Ports and start Auxiliary suction