



Advancing Healthcare Worldwide®

iReceptal® Mini

Digital Surgical Suction System

Site Preparation and Installation

100-120 VAC System REF iRS551-01

100-120 VAC System REF iRS552-01

220-240 VAC System REF iRS551-02

220-240 VAC System REF iRS552-02

Instructions For Use

100-120 VAC iReceptal Docking Station, **REF** iRD502-01

220-240 VAC iReceptal Docking Station, **REF** iRD502-02

R_x ONLY

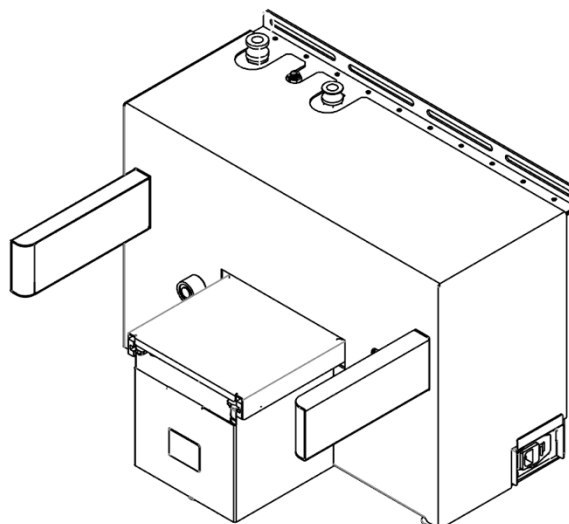

Contents

1. Introduction.....	3
1.1. Conventions.....	3
1.2. Contact Information	3
1.2.1 International Addresses.....	3
1.3. Intended Purpose	4
1.4. Contraindications For Use	4
1.5. For Use With.....	4
1.6. User/Patient Safety.....	4
1.6.1 General Safety	4
1.6.2 Electrical Safety.....	5
1.6.3 Environmental/Biological.....	6
2. System Overview.....	6
2.1 System Operation	6
2.2 Features.....	7
2.3 Symbols	8
3. Instructions	9
3.1 To Install the Docker.....	9
3.1.1 To Install the Docker and Connect Utilities	10
3.1.2 To Apply Power, Water, and Detergent	11
3.2 To Test the Docker	12
3.2.1 To Prepare the Rover	12
3.2.2 To Prepare the Docker	12
3.2.3 To Perform a Wash Cycle.....	13
3.3 To Shut Down the Docker.....	13
4. Inspection and Maintenance	14
4.1 To Install the Docking Detergent Bottle.....	14
5. References	15
5.1 Cleaning and Disinfection.....	15
5.2 To Wipe Down the Docker.....	15
5.3 Storage and Handling.....	16
5.4 Disposal/Recycle	16
6. Troubleshooting	16
6.1 Error Messages.....	17
7. Specifications	18
8. Electromagnetic Compatibility.....	19

1. Introduction

This Instructions For Use manual is the most comprehensive source of information for your product. Keep and consult this reference manual during the life of the product.

1.1. Conventions

The following conventions are used in this manual:

WARNING	A warning highlights a safety-related issue. ALWAYS comply with this information to prevent patient or healthcare staff injury.
CAUTION	A caution highlights a product reliability issue. ALWAYS comply with this information to prevent product damage.
NOTE	A note supplements and/or clarifies procedural information.

1.2. Contact Information

For additional information, including safety information, or in-service training, contact your AMSINO sales representative or call AMSINO iReceptal Customer Service.

Note - The user and/or patient should report any serious product-related incident to both the manufacturer and the Competent Authority of the European Member State where the user and/or patient is established.

1.2.1 International Addresses

1.3. Intended Purpose

The iReceptal Mini Digital Surgical Suction System is intended to be used in the operating room, pathology, surgical centers, and doctor's offices to collect and dispose of surgical fluid waste as well as collect smoke generated from electrocautery or laser devices.

1.4. Contraindications For Use

The iReceptal Mini Digital Surgical Suction System is **contraindicated against:**

- Connection directly to **chest tubes**.
- Connection to **closed wound drainage systems**.

1.5. For Use With

The following components are required to be used with the equipment described in this manual to create a complete system:

Description	REF
iReceptal 3 Docking Detergent	iRC003
Enzymatic Cleaner (Neutral (pH 7), non-corrosive, low-foam detergent)	Commercially available
100-120VAC Rover (compatible with 100-120VAC Receptal Docking Station REF iRD502-01)	REF iRR551-01
100-120VAC Rover (compatible with 100-120VAC iReceptal Docking Station REF iRD502-01)	REF iRR552-01
220-240VAC Rover (compatible with 220-240VAC iReceptal Docking Station REF iRD502-02)	REF iRR551-02
220-240VAC Rover (compatible with 220-240VAC iReceptal Docking Station REF iRD502-02)	REF iRR552-02
Power Cord(s) 2.5 m	iRA10X-XX

*The X-XX suffix is a two or three-digit code that indicates the region and type of power cord provided.

NOTE: For a complete list of accessory information, contact your AMSINO sales representative or call AMSINO iReceptal Mini Digital Surgical Suction System Customer Service.

1.6. User/Patient Safety

WARNINGS:

1.6.1 General Safety

- Before using any system component, or any component compatible with this system, read and understand the instructions. Pay particular attention to WARNING information. Become familiar with the system components prior to use.

- Only trained and experienced healthcare professionals may use this equipment.
- Healthcare professionals should be thoroughly familiar with the instructions for use, handling characteristics, and the indicated and intended uses of this equipment. Contact your AMSINO sales representative or AMSINO iReceptal Mini Digital Surgical Suction System Customer Service for in-service training.
- DO NOT disassemble, modify, service, or repair any system component or accessory, unless otherwise specified. Call AMSINO iReceptal Mini Digital Surgical Suction System Customer Service.
- Upon initial receipt and before each use, inspect each component for damage. DO NOT use any equipment if damage is apparent or the inspection criteria are not met. See the Inspection and Maintenance section for inspection criteria.
- ALWAYS operate the equipment within the specified environmental condition values. See the Specifications section.
- This equipment is suitable to use in a professional healthcare facility environment.

1.6.2 Electrical Safety

- Use only AMSINO-approved system components and accessories, unless otherwise specified. Using other electronic components and accessories may result in increased electromagnetic emissions or decreased electromagnetic immunity of the system.
- Take special precautions regarding electromagnetic compatibility (EMC) when using medical electrical equipment like this system. Install and place this system into service according to the EMC information contained in this manual. See the Specifications section. Portable and mobile radio frequency (RF) communications equipment can affect the function of this system.
- ELECTRICAL SHOCK HAZARD-ALWAYS connect this equipment to a hospital-grade, facility power receptacle with protective earth (ground). Failure to comply may cause electrical shock and result in patient or healthcare staff injury.
- DO NOT stack or place equipment adjacent to the product. If such a configuration is necessary, observe the configuration to ensure that electromagnetic interference does not degrade performance.
- DO NOT use the product in a magnetic resonance imaging (MRI) environment. Using the product in an MRI environment could affect the function of the system.
- The power switch is used to disconnecting the device from the facility power. Do not position Rover so that disconnecting the device is difficult.
- This device complies with Part 15 of the FCC Rules. Operation is subject to the following two conditions:
 - (1) This device may not cause harmful interference, and
 - (2) This device must accept any interference received, including interference that may cause undesired operation.
- This device complies with Industry Canada licence-exempt RSS standard(s). Operation is subject to the following two conditions:
 - (1) this device may not cause interference, and
 - (2) this device must accept any interference, including interference that may cause undesired operation of

the device.

- This equipment complies with FCC/IC RSS-102 radiation exposure limits set forth for an uncontrolled environment. This equipment should be installed and operated with minimum distance 20cm between the radiator & your body.
- Under Industry Canada regulations, this radio transmitter may only operate using an antenna of a type and maximum (or lesser) gain approved for the transmitter by Industry Canada. To reduce potential radio interference to other users, the antenna type and its gain should be so chosen that the equivalent isotropically radiated power (e.i.r.p.) is not more than that necessary for successful communication.

1.6.3 Environmental/Biological

- FIRE HAZARD – DO NOT use this equipment in areas in which flammable anesthetics or flammable agents are mixed with air, oxygen or nitrous oxide. Failure to comply may cause a fire and result in burn injury or property damage.
- BLOODBORNE PATHOGEN HAZARD
 - The Bloodborne Pathogens Standard provided by the United States Occupational Safety and Health Association (US OSHA 29 CFR 1910.1030) requires those with employees having occupational exposure to potentially infectious materials to establish a written Exposure Control Plan. The Exposure Control Plan is designed to eliminate or minimize employee exposure through use of personal protective equipment (PPE), appropriate vaccinations (e.g. hepatitis B), and other control measures.
 - ALWAYS wear PPE when operating or handling this equipment.
 - ALWAYS follow local regulations regarding proper handling and disposal of biohazard waste.

Failure to comply may cause infection and result in healthcare staff injury.

- CONTAMINATION HAZARD-ALWAYS follow local regulations for safe handling, recycling, and disposal of biohazard fluid waste and equipment. See Disposal/Recycle section. Failure to comply may cause environmental contamination and result in injury.

2. System Overview

2.1 System Operation

The iReceptal Docking Station (docker) is a component of the iReceptal Mini Digital Surgical Suction System. The iReceptal Rover (rover), another component of the system, is a mobile unit used to suction and collect fluid waste and surgical smoke from a surgical site in an operating room.

After collection, the rover is relocated and mated to the docker. Once the rover is connected to the docker, the emptying of the fluid waste and cleaning of the canisters occurs automatically (Figure 1).

The rover canisters are rinsed with clean water and Detergent (recommend iReceptal Docking Detergent REF iRC003 or Enzymatic Cleaner (Neutral (pH 7), non-corrosive, low-foam detergent)) to clean the canisters of any residual fluid waste (Figure 2). A bottle of detergent is connected to the docker.

Figure 1 To Empty the Canisters

Figure 2 To Clean the Canister

2.2 Features

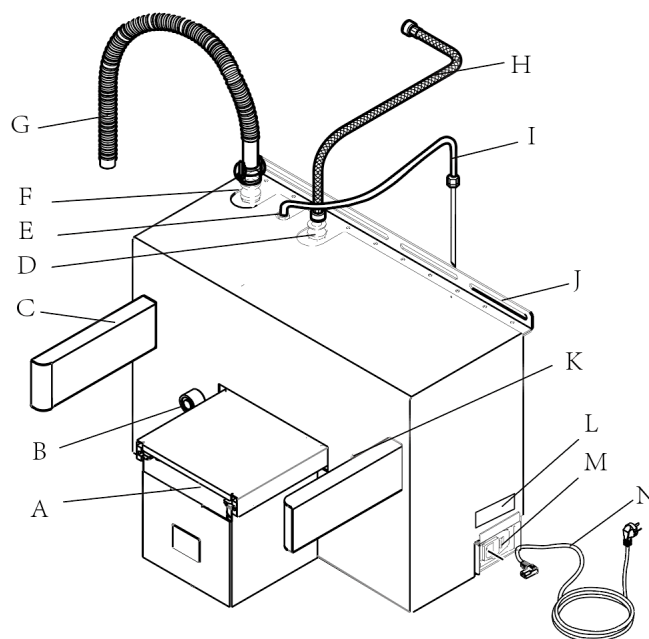











Figure 3 Docking Station

A	Power and Fluid Connectors – When the rover is connected to the docker, the rover receives power from the docker. Four fluid connectors are also present. Two connectors allow fresh water to enter the rover and provide for the disposal of waste water from the rover. The other two connectors allow steam water to enter the rover.
B	Magnet– Provide for the automatic connection of the rover to the docker.
C	Guides (two) – Facilitate the alignment of the rover to the docker.
D	Water Inlet Port – Allows fresh water to enter the rover when the rover is connected to the docker.

E	Detergent Inlet Port – Allows detergent to enter the rover’s fluid collection system to facilitate cleaning when the rover is connected to the docker.
F	Waste Outlet Port – Allows for the disposal of fluid waste from the rover when the rover is connected to the docker.
G	Water Inlet Hose – Allows fresh water to flow from the facility water source to the docker water inlet port.
H	Waste Outlet Hose – Allows fluid waste to flow from the docker waste outlet port to the drain of the facility waste disposal system.
I	External Detergent Hose Assembly – Allows detergent to flow from the detergent bottle to the docker detergent inlet port. The cap secures the hose assembly to the Docking Detergent bottle.
J	Mounting Bracket – Allows for the secure installation of the docker to a flat wall surface using mounting hardware (not supplied).
K	Infrared Communication Port – Allow infrared data transfer between the docker and rover. Data transfer is necessary during the docking procedure.
L	Specification Label – Includes serial number, and part number information
M	Power Cord Receptacle / Power Switch– Allows for the connection of facility power using the docker power cord.
N	Power Cord – Allows for the connection of facility electrical power to the docker. Power cord configurations may vary. See the Accessories section for options.

2.3 Symbols

The symbols located on the equipment and/or labeling are defined in this section.

Symbol	Description
	ON (POWER)
	OFF (POWER)
	ALTERNATING CURRENT (AC)
	General warning sign (yellow); ISO 7010-W001
	Consult instructions for use
	Follow instructions for use(blue);I SO 7010-M002
	This symbol is located near the protective ground locations on this device
	DETERGENTADD INLET PORT
	WASTE OUTLET PORT Biological risks; ISO 7000-0659

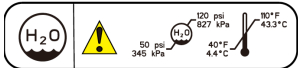
	WATER INLET PORT
IP22	Degree of protection against ingress of water. The device has an IP22 degree of protection against liquids (drip-proof).

3. Instructions

3.1 To Install the Docker

⚠ WARNING: HEAVY EQUIPMENT – ALWAYS have more than one person unpack and move this equipment from the shipping pallet using the lift points (Figure 4). See the Specifications section for docker weight. Failure to comply may result in personal injury.

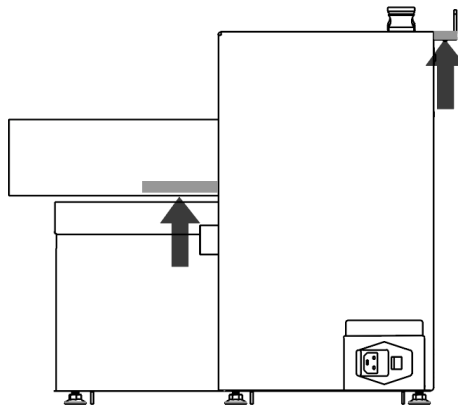

Figure 4 Docker Lift Points

CAUTIONS:

- Make sure the pressure and temperature values of the facility water supply are within the required specified ranges. See the Specifications section.
- If mounting the docker to a wall, make sure no gap exists between the docker mounting bracket and the wall. ALWAYS align the mounting hardware (not supplied) with the wall studs to make sure the docker is mounted to the wall securely. Failure to comply may cause inadvertent docker movement and result in wall or product damage.
- ALWAYS use the correct power cord. Configurations may vary. See the For use with section for power cord options

NOTES:

- Only individuals trained and experienced in the maintenance of reusable medical devices should install, inspect, and test this equipment.
- The docker is installed in a utility closet or disposal area with access to electrical power, a water supply,

and a fluid waste drain. The healthcare facility is responsible for the preparation of the installation site and the availability of utilities. See the Specifications section for electrical power, water, and drainage requirements. Make sure the installation area meets utility and space requirements (Figure 5).

- If the installation site does not meet local ventilation requirements, obtain and install a ventilation device that will meet the necessary local requirements.
- The docker is equipped with an internal backflow prevention device. See the Specifications section for details. Refer to local plumbing codes to determine whether an external backflow prevention device is also required.
- Make sure the plumbing configuration is NOT susceptible to water hammer conditions.
- Make sure the waste outlet hose is connected properly to minimize the escape of noxious fumes and odors.

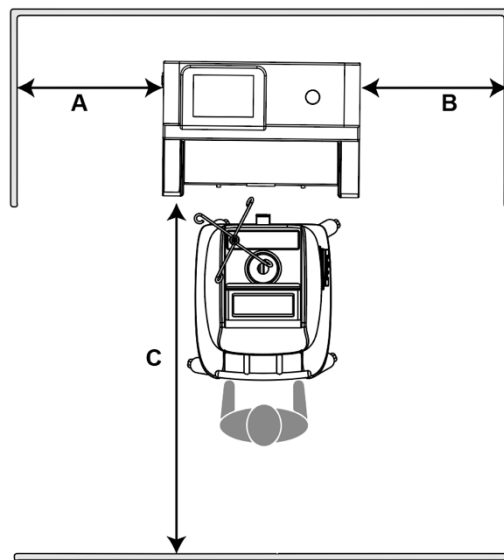

Figure 5 Minimum Floor Space Requirements

A	Left-Side Clearance	No minimum requirement
B	Right-Side Clearance	15 cm
C	Front Clearance	120cm

3.1.1 To Install the Docker and Connect Utilities

1. Place the docker on the floor and against a wall with access to electrical power, water, and a fluid waste disposal drain.
2. Recommended: Install mounting screws (not supplied) through the mounting bracket of the docker and secure the docker to the wall.

NOTE: If allowed by current local building and electrical codes, mounting the docker to the wall is strongly recommended. The docker is not to be installed in a patient environment.

3. Connect the water inlet hose between the water inlet port of the docker and the facility water supply.
4. Connect the waste outlet hose to the waste outlet port of the docker and the drain emptying into the fluid waste disposal system.
5. Connect the power cord between the electrical receptacle of the docker and the facility electrical power source.

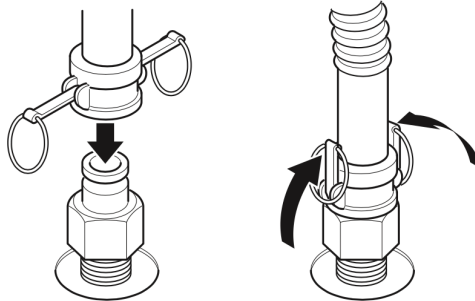

Figure 6 To Connect the Waste Outlet Hose

3.1.2 To Apply Power, Water, and Detergent

1. Press the power switch ON. Make sure the power switch illuminates.
2. Open the facility water valve to allow water to flow to the docker. Inspect the water supply connections for any leaks. Repair any plumbing to stop leakage if necessary.
3. Push the end of the external detergent hose into the detergent inlet port until it stops. Gently tug on the detergent hose to make sure the hose is secure.

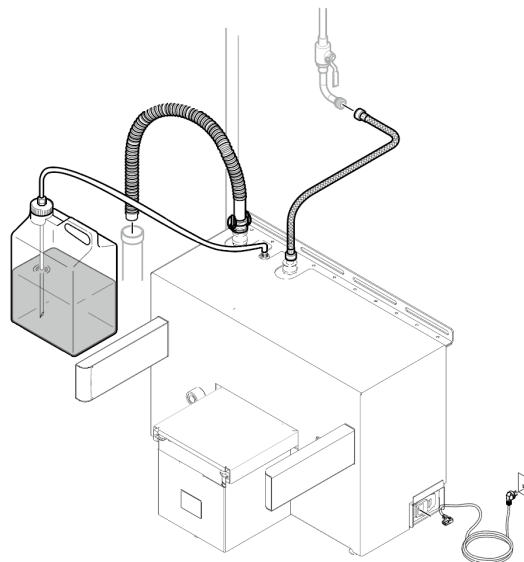



Figure 7 To Apply Power, Water, and Detergent

3.2 To Test the Docker

 **WARNING:** ALWAYS keep hands out and away from the mating surfaces of the rover and docker during the docking procedure to avoid a pinch point hazard.

CAUTIONS:

- DO NOT put any objects, including hoses, tubes, towels or detergent bottles, on or over the docker enclosure. Failure to comply may cause corrosion.
- DO NOT allow fluid of any kind to spill directly onto the exterior surface of the electrically-powered docker. Failure to comply may cause corrosion or product failure.

NOTES:

- Only individuals trained and experienced in the maintenance of reusable medical devices should install, inspect, and test this equipment.
- Make sure the rover is operating properly. See the instructions for use supplied with the rover.
- The docker provides power to the rover during the docking process.
- While the rover is docked, DO NOT lock the rover casters.

3.2.1 To Prepare the Rover

NOTE: See the instructions for use supplied with the rover for more information about rover preparation.

1. Connect the rover to facility electrical power using the power cord.
2. Push the power switch to the ON position.
3. Read the WARNING message on the user interface, then tap the OK key to access the CONTROL screen.
4. Install a disposable manifold into manifold port.
5. Attach a suction tube to one manifold port on manifold. Make sure all the other manifold ports are capped.
6. Place the attached suction tube into a sink filled with water.
7. Using the procedural steps provided in the instructions for use supplied with the rover, suction about two liters of water into each canister.
8. After the canister is filled with two liters of water, push the rover power switch to the OFF position.
9. Disconnect the rover from facility electrical power. Wrap the power cord around the cord bracket.
10. Remove the disposable manifold and suction tube.

3.2.2 To Prepare the Docker

1. Make sure the power switch is in the ON position and illuminated.

2. Make sure the bottle of Detergent is connected and has detergent to perform a wash cycle.

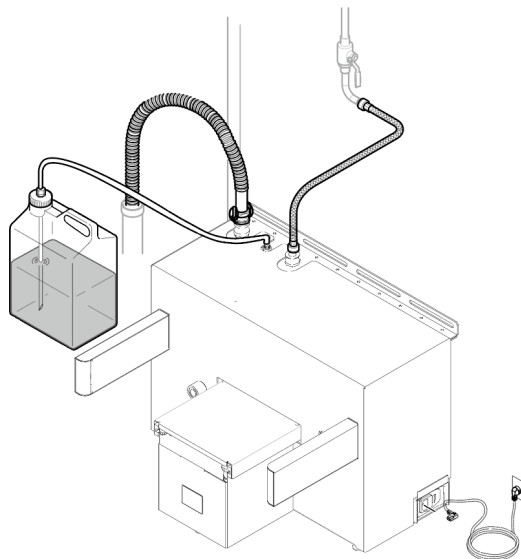

Figure 8 To Prepare the Docker

3.2.3 To Perform a Wash Cycle

1. Push the rover toward the docker and between the guides until the rover and docker attach automatically.

NOTE: If a specific wash cycle is not selected within 10 seconds, the default wash cycle will be performed automatically.

2. Perform a wash cycle using the procedure in the instructions for use supplied with the rover.
3. During the wash cycle, inspect all the docker plumbing and connections for any leakage. If leakage occurs, repair as required.

NOTES:

- During the first rover docking procedure, the information on the user interface display may appear inconsistent. The procedure may also take a few more minutes than specified in the Wash Cycle Options table. Both conditions are normal and temporary.
- If a specific wash cycle is not selected within ten seconds, the “Normal Wash” cycle will be performed automatically. See the Wash Cycle Options table.
- After successfully testing, the docker is ready for use.

3.3 To Shut Down the Docker

The docker does not need to be shut down between uses. To remove facility power from the docker, push the power switch to the OFF position.

4. Inspection and Maintenance

⚠ WARNINGS:

- Upon initial receipt and before each use, inspect each component for damage. DO NOT use any equipment if damage is apparent or the inspection criteria are not met.
- DO NOT disassemble, modify, service, or repair any system component or accessory, unless otherwise specified. Call AMSINO iReceptal Customer Service.

NOTES:

- Only individuals trained and experienced in the maintenance of reusable medical devices should install, inspect, and test this equipment.
- For service, contact your AMSINO sales representative or call AMSINO iReceptal Customer Service. Outside the US, contact your nearest AMSINO subsidiary.
- Maintenance documentation for this equipment is available upon request to AMSINO-authorized service personnel only.

INTERVAL	INSPECTION CRITERIA	ACTION
Before initial use	Make sure the equipment has been tested before first use.	See the To Test the Docker section.
Before each use and after each cleaning	Check equipment for damage or missing components.	If damage is apparent, replace the equipment.
	Check power cord for cuts.	
	Check power cord receptacle for bent pins or bent contacts.	
Six months	Check the plumbing connections and hoses for leaks.	Repair any plumbing to stop leakage as required. Replace leaking hoses as required.
As required	Check the two infrared communication ports for any obstructions.	Remove any obstruction covering the infrared communication ports, including hoses, tubes, and towels.

NOTE: If any component must be discarded, see the Disposal/ Recycle section.

4.1 To Install the Docking Detergent Bottle

⚠ WARNINGS:

- The iReceptal Detergent REF IRC003 or Enzymatic Cleaner (Neutral (pH 7), non-corrosive, low-foam detergent) is an irritant to eyes and skin. ALWAYS wear protective gloves and eye protection to avoid contact with skin and eyes.

- In case of contact with eyes, rinse eyes immediately with plenty of water. See the Material Safety Data Sheet (MSDS) supplied with the iReceptal Docking Detergent for first aid information.
- DO NOT spill the detergent. Spills will be slippery and may result in a slip/fall hazard.
- ALWAYS follow the current local regulations governing environmental protection to recycle or dispose of the bottle. DO NOT reuse the empty container.

CAUTION: Use only AMSINO iReceptal Detergent REF IRC003 or Enzymatic Cleaner (Neutral (pH 7), non-corrosive, low-foam detergent) with the docker. Failure to comply will result in damage to rover and docker internal components.

1. Before installing a new bottle of detergent, shake the bottle well.
2. Remove the cap from the new bottle of detergent. Put the detergent hose assembly into the new bottle.
3. Twist the cap to secure the detergent hose assembly in the bottle.
4. If a detergent bottle was replaced, rinse the empty bottle, put the replacement cap on the bottle, and dispose of the bottle properly. See the Disposal/Recycle section.

5. References

5.1 Cleaning and Disinfection

CAUTIONS:

- DO NOT immerse any system component in liquid. DO NOT allow liquids or moisture to enter any electrical connection.
- DO NOT sterilize any system component.
- DO NOT use solvents, lubricants, or other chemicals, including glutaraldehyde or similar chemical cleaners, unless otherwise specified. Use of unapproved cleaners may cause system damage.

Recommended Equipment

- Personal Protective Equipment (PPE) as recommended by the disinfectant supplier (minimum: gown, gloves, face/eye shield)
- Hospital grade disinfectant
- Soft, lint-free cloth

5.2 To Wipe Down the Docker

1. Wipe the external surfaces of the docker with a soft, lint-free cloth moistened with a non-abrasive, hospital disinfectant prepared according to the manufacturer's instructions. Make sure all surfaces remain visibly wet at room temperature.
2. Remove any excess disinfectant solution using a soft, lint-free cloth moistened with water if required by the instructions supplied by the disinfectant manufacturer.

3. Thoroughly clean the docker's infrared communication ports to make sure the rover and docker can communicate and function properly.
4. Inspect the docker. See the Inspection and Maintenance section.

5.3 Storage and Handling

CAUTIONS:

- ALWAYS store and transport the equipment within the specified environmental condition values throughout its useful life. See the Specifications section.
- ALWAYS call AMSINO iReceptal Customer Service before transporting or storing this equipment in freezing conditions. Failure to comply will cause the expansion of frozen internal fluid to damage the equipment.

5.4 Disposal/Recycle

WARNING:

BLOODBORNE PATHOGEN AND CONTAMINATION HAZARDS –

- ALWAYS follow local regulations for safe handling, recycling, and disposal of biohazardous fluid waste and equipment.
- Call iReceptal Customer Service for docker decontamination procedures.
- Discarded electromedical equipment must not be disposed together with waste but must be collected separately to guarantee ecologically correct disposal to prevent dispersion of potential pollutants into the environment. Please hand in the device at the end of its useful life to the local collection and recycling point for electrical and electronic devices.

Failure to comply may cause environmental contamination or infection and result in personal injury.



Per the European Community (EC) Waste Electrical and Electronic Equipment (WEEE) Directive 2012/96/EC, product must be collected separately. DO NOT dispose of as unsorted municipal waste. Contact local distributor for disposal information. Ensure infected equipment is decontaminated prior to recycling.

6. Troubleshooting

NOTE: For service, contact your AMSINO sales representative or call AMSINO iReceptal Customer Service.

PROBLEM	CAUSE	SOLUTION
Power switch does not illuminate in the ON position.	Power cord is not connected or is loosely connected.	Make sure the power cord is connected securely.

The rover will not dock or an error has occurred during the docking procedure.	The infrared communication ports are obstructed.	Make sure the docker's infrared communication ports are not obstructed by any tubes, hoses or towels. Remove any dirt or debris from the rover's infrared communication window.
	The rover is not completely connected to the docker.	Push the rover forward enough to complete a docker-rover interface connection.
	The facility water valve is shut off.	Turn on the facility water valve.
	The docker is damaged.	Contact Customer Service.
Water inlet hose is leaking.	Water inlet hose connection is not secure.	Make sure the water inlet hose connection is secure.
	Water inlet hose is damaged.	Replace the water inlet hose.
Waste outlet hose is leaking.	Waste outlet hose connection is not secure.	Make sure the waste outlet hose connection is secure.
	Waste outlet hose is damaged.	Replace the waste outlet hose.
The docker does not dispense detergent during the cleaning cycle.	The bottle of detergent is empty.	Replace the bottle of the detergent. See the For Use With section and the To Install the Docking Detergent Bottle section.
	The detergent inlet tube is not connected securely to the detergent inlet port of the docker.	Connect the detergent inlet tube to the detergent inlet port of the docker securely.
	If the problem persists, the docker detergent pump may be damaged.	Contact Customer Service.
Sporadic electrical interference is experienced.	Electrical noise is present.	Turn off all the electrical equipment not in use in the room.
		Relocate the electrical equipment to maximize the distance between the equipment. Increase spatial distance.
		Plug equipment into different outlets.

6.1 Error Messages

NOTE: For error message information, see the instructions for use supplied with the rover.

7. Specifications

Model:		
REF	iRD502-01	iRD502-02
Electrical Power Requirements:	100V-120V~, 60 Hz, 15A	220V-240V~, 50/60 Hz, 10.0 A
Power inlet module	Power switch with 250V fuses on neutral and line connection	
European Conformity:		
Product Safety Certification:	IEC 60601-1:2020 Medical electrical equipment – Part 1: General requirements for basic safety and essential performance IEC 60601-1-2:2020 Collateral Standard: Electromagnetic disturbances – Requirements and tests	
Dimensions:	Width: 64.5cm Height: 46.5cm Depth: 53cm	
Mode of Operation:	Continuous	
Mass	50kg	
Equipment Classification:	Class I Medical Electrical (ME) Equipment	
Ingress Protection (IP):	IP22	
Light Emitting Diode (LED) Classification (infrared communication windows):	WARNING: INVISIBLE LED RADIATION DO NOT VIEW DIRECTLY WITH OPTICAL INSTRUMENTS CLASS 1M LED PRODUCT — Viewing the laser output with certain optical instruments (for example, eye loupes, magnifiers and microscopes) within a distance of 100 mm may pose an eye hazard.	
Ground Type:	Protective Earth (ground); when connected to facility power	
Lifetime	Eight-years	
Water Requirements: Pressure Range: Temperature Range: Fitting Connection: Water Quality: Water Usage: Facility Backflow Prevention Device:	345 kPa to 827 kPa [50 to 120 psi] 4.4 to 43.3 °C [40 to 110 °F]. Facility source is equipped with a Rc1/2 Female (1/2" BSPT Taper Female Thread) with a shut-off valve. Potable tap water Approximately 10 liters per rinse cycle at default settings on standard cycle; water usage fluctuates due to selected cycle and facility flow. Refer to local plumbing codes to determine whether an external backflow prevention device is required.	
Drainage Requirements: :	Floor drain or permanent service connection per local plumbing codes; 2.44 m [8 feet] connection distance (maximum)	
Water Inlet Hose:	inner diameter: 25 cm [0.50 inch] length: 3m	
Waste Outlet Hose:	inner diameter: 1.27 cm [0.50 inch] length: 3m	
Waste Pump Outlet Flow:	23L/min	
Environmental Conditions:	Operation	Storage and Transportation (before initial use) Storage and Transportation (after initial use)

Temperature Limitation			
Humidity Limitation			
Atmospheric Pressure Limitation:			

8. Electromagnetic Compatibility

Guidance and Manufacturer's Declaration

Below cables information are provided for EMC reference.

Cable	Max. cable length, Shielded/unshielded		Number	Cable classification
AC Power Line	3.0m	Unshielded	1 Set	AC Power

Important information regarding Electro Magnetic Compatibility (EMC)

This electrical medical equipment needs special precautions regarding EMC and put into service according to the EMC information provided in the user manual; The equipment conforms to this IEC 60601-1-2 Edition 4.1 standard for both immunity and emissions. Nevertheless, special precautions need to be observed:

- The equipment with no ESSENTIAL PERFORMANCE is intended used in Professional healthcare facility environment
- WARNING:** Use of this equipment adjacent to or stacked with other equipment should be avoided because it could result in improper operation. If such use is necessary, this equipment and the other equipment should be observed to verify that they are operating normally”.
- The use of accessories, transducers and cables other than those specified or provided by the manufacturer of this equipment could result in increased electromagnetic emissions or decreased electromagnetic immunity of this equipment and result in improper operation.
- WARNING:** Portable RF communications equipment (including peripherals such as antenna cables and external antennas) should be used no closer than 30 cm (12 inches) to any part of this product, including cables specified by the manufacturer. Otherwise, degradation of the performance of this equipment could result.”
- WARNING:** If the use location is near (e.g. less than 1.5 km from) AM, FM or TV broadcast antennas, before using this equipment, it should be observed to verify that it is operating normally to assure that the equipment remains safe with regard to electromagnetic disturbances throughout the expected service life.

EMI Compliance Table (Table 1)

Table 1 - Emission

Phenomenon	Compliance	Electromagnetic environment
RF emissions	CISPR 11 Group 1, Class A	Professional healthcare facility environment
Harmonic distortion	N/A	Professional healthcare facility environment
Voltage fluctuations and flicker	N/A	Professional healthcare facility environment

NOTE The EMISSIONS characteristics of this equipment make it suitable for use in industrial areas and hospitals (CISPR 11 class A). If it is used in a residential environment (for which CISPR 11 class B is normally required) this equipment might not offer adequate protection to radio-frequency communication services. The user might need to take mitigation measures, such as relocating or re-orienting the equipment.

EMS Compliance Table (Table 2-4)

Table 2 - Enclosure Port

Phenomenon	Basic EMC standard	Immunity test levels
		Professional healthcare facility environment
Electrostatic Discharge	IEC 61000-4-2	±8 kV contact ±2kV, ±4kV, ±8kV, ±15kV air
Radiated RF EM field	IEC 61000-4-3	3V/m 80MHz-2.7GHz 80% AM at 1kHz
Proximity fields from RF wireless communications equipment	IEC 61000-4-3	Refer to table 3
Rated power frequency magnetic fields	IEC 61000-4-8	30A/m 50Hz or 60Hz
Proximity fields	IEC 61000-4-39	134,2 kHz Pulse modulation 2,1kHz, 65 A/m 13,56 MHz Pulse modulation 50kHz, 7,5 A/m

Table 3 – Proximity fields from RF wireless communications equipment

Test frequency (MHz)	Band (MHz)	Immunity test levels
		Professional healthcare facility environment

385	380-390	Pulse modulation 18Hz, 27V/m
450	430-470	FM, ± 5 kHz deviation, 1kHz sine, 28V/m
710	704-787	Pulse modulation 217Hz, 9V/m
745		
780		
810	800-960	Pulse modulation 18Hz, 28V/m
870		
930		
1720	1700-1990	Pulse modulation 217Hz, 28V/m
1845		
1970		
2450	2400-2570	Pulse modulation 217Hz, 28V/m
5240	5100-5800	Pulse modulation 217Hz, 9V/m
5500		
5785		

Table 4 – Input a.c. power Port

Phenomenon	Basic EMC standard	Immunity test levels
		Professional healthcare facility environment
Electrical fast transients/burst	IEC 61000-4-4	± 2 kV 100kHz repetition frequency
Surges Line-to-line	IEC 61000-4-5	± 0.5 kV, ± 1 kV
Surges Line-to-ground	IEC 61000-4-5	± 0.5 kV, ± 1 kV, ± 2 kV
Conducted disturbances induced by RF fields	IEC 61000-4-6	3V, 0.15MHz-80MHz 6V in ISM bands between 0.15MHz and 80MHz 80%AM at 1kHz
Voltage dips	IEC 61000-4-11	0% U_T ; 0.5 cycle At 0°, 45°, 90°, 135°, 180°, 225°, 270° and 315°
		0% U_T ; 1 cycle and 70% U_T ; 25/30 cycles Single phase: at 0°
Voltage interruptions	IEC 61000-4-11	0% U_T ; 250/300 cycles